

FEATURES

- 2.5V~5.5V Power supply.
- Thermal shutdown Protection.
- Low current shutdown mode
- No output capacitors and networks or bootstrap capacitors required
- Low noise during turn-on and turn-off transitions
- Shutdown pin high active.
- Lead free and green package available. (RoHS Compliant)
- Space Saving Package
-- 8-pin 150 mil SOP.

GENERAL DESCRIPTION

The LY8896 is a 1.4 Watt audio power amplifier. And the LY8896 primarily designed for high quality application in other portable communication device. It is capable of driving 8Ω speaker load at a continuous average output of 1.4W / 10% distortion (THD+N) from a 5.0V power supply.

A feature of the LY8896 amplifier to switch BTL mode. And the LY8896 audio amplifier features low power consumption shutdown mode. It is achieved by driving the shutdown pin with logic high. Besides the LY8896 has an internal thermal shutdown protection feature.

The LY8896 amplifier was designed specifically to provide high quality output power with a minimal amount of external components. The LY8896 does not require output capacitors, and the LY8896 is ideally suited for other low voltage applications or portable electronic devices where minimal power consumption is a primary requirement.

APPLICATION

- Portable electronic devices
- Mobile Phones
- PDAs

PIN CONFIGURATION

LY8896 8 Pin SOP (Top View)

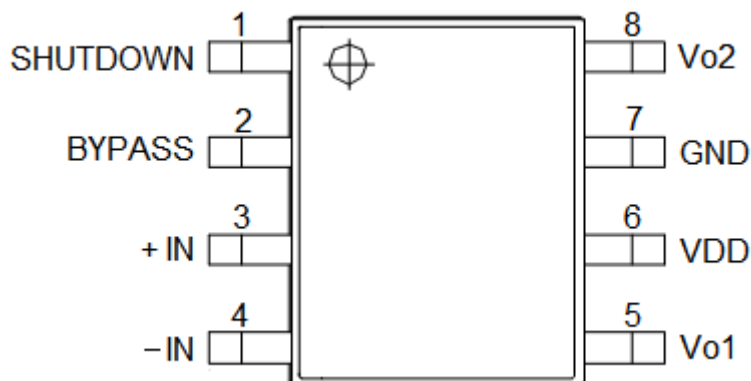

PIN DESCRIPTION

SYMBOL	Pin No.	DESCRIPTION
	SOP8	
SHUTDOWN	1	Shutdown the device.
BYPASS	2	Bypass pin
+IN	3	Positive Input
-IN	4	Negative Input
Vo1	5	Negative output
V _{DD}	6	Power Supply
GND	7	Ground
Vo2	8	Positive Output

APPLICATION CIRCUIT

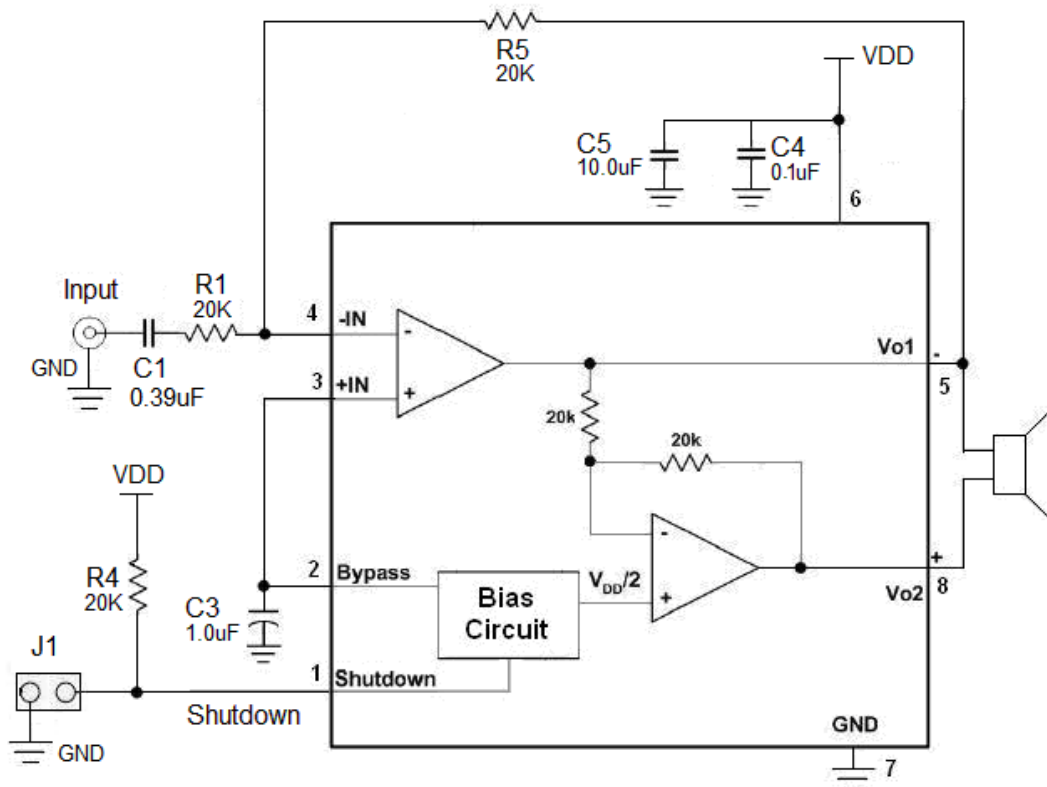
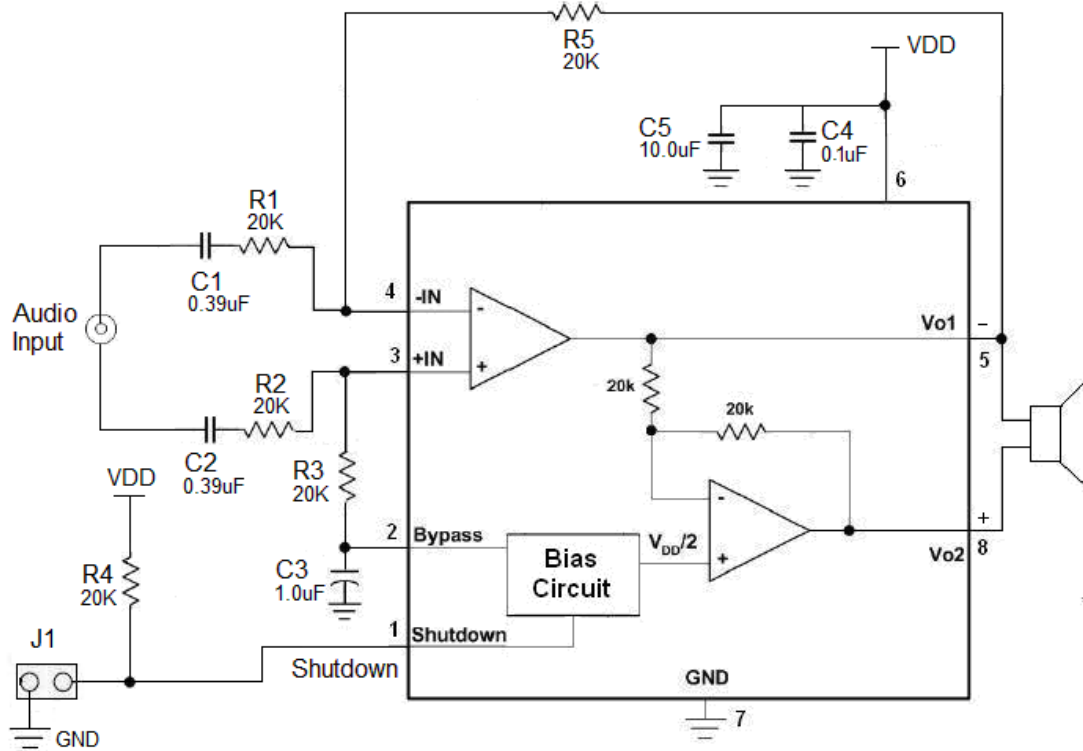

Figure 1. LY8896 application schematic with single-ended input

Figure 2. LY8896 application schematic with differential input
ABSOLUTE MAXIMUM RATINGS*

PARAMETER	SYMBOL	RATING	UNIT
Supply Voltage	V _{DD}	6.0	V
Operating Temperature	T _A	-40 to 85 (I grade)	°C
Input Voltage	V _I	-0.3V to V _{DD} +0.3V	V
Storage Temperature	T _{STG}	-65 to 150	°C
Power Dissipation	P _D	Internally Limited	W
ESD Susceptibility	V _{ESD}	2000	V
Junction Temperature	T _{JMAX}	150	°C
Soldering Temperature (under 10 sec)	T _{SOLDER}	260	°C



DC ELECTRICAL CHARACTERISTICS (T_A=25°C)

PARAMETER	SYMBOL	TEST CONDITION	MIN.	TYP.	MAX.	UNIT	
Power Supply Current	I _{DD}	V _{IN} = 0V, I _o = 0A, 8Ω Load	V _{DD} = 5.0V	-	6.0	18.0	mA
			V _{DD} = 3.0V	-	5.0	15.0	mA
Shutdown Current	I _{SD}	V _{SHUTDOWN} = V _{DD}	-	0.1	2.0	μA	
Output Offset Voltage	V _{OS}		-	7.0	50.0	mV	
Resistor Output to GND	R _{OUT-GND}		-	9.5	-	kΩ	
Output Power	P _o	THD = 10%, f=1kHz, R _L =8Ω	V _{DD} = 5.0V	-	1.4	-	W
				-	1.1	-	
		THD = 10%, f=1kHz, R _L =8Ω	V _{DD} = 3.0V	-	480	-	mW
				-	375	-	
Total Harmonic Distortion+ Noise	THD+N	P _o =780 mWrms; f = 1kHz	V _{DD} = 5.0V	-	0.1	-	%
		P _o =265 mWrms; f = 1kHz	V _{DD} = 3.0V	-	0.12	-	%
Power Supply Rejection Ratio	PSRR	V _{ripple} = 200mV sine p-p, Input = Floating	V _{DD} = 5.0V	-	66 (f = 217Hz) 66 (f = 1kHz)	-	dB
			V _{DD} = 3.0V	-	62 (f = 217Hz) 62 (f = 1kHz)	-	dB
Wake-up time	T _{wu}	Bypass Cap.=1.0uF	V _{DD} = 5.0V	-	145	-	ms
			V _{DD} = 3.0V	-	82	-	ms
Thermal Shutdown Temperature	T _{SD}		150	170	190	°C	
Shut Down Time	T _{SdT}	8 Ω load	-	1.0	-	ms	

ORDERING INFORMATION

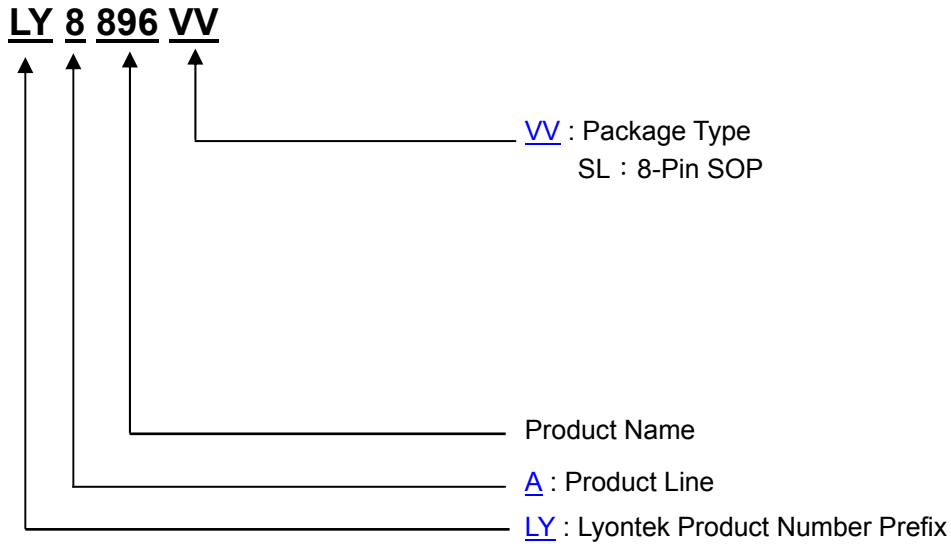

TYPICAL PERFORMANCE CHARACTERISTICS

Figure 3
THD+N vs Frequency at $R_L=8\Omega$, $A_V=2$

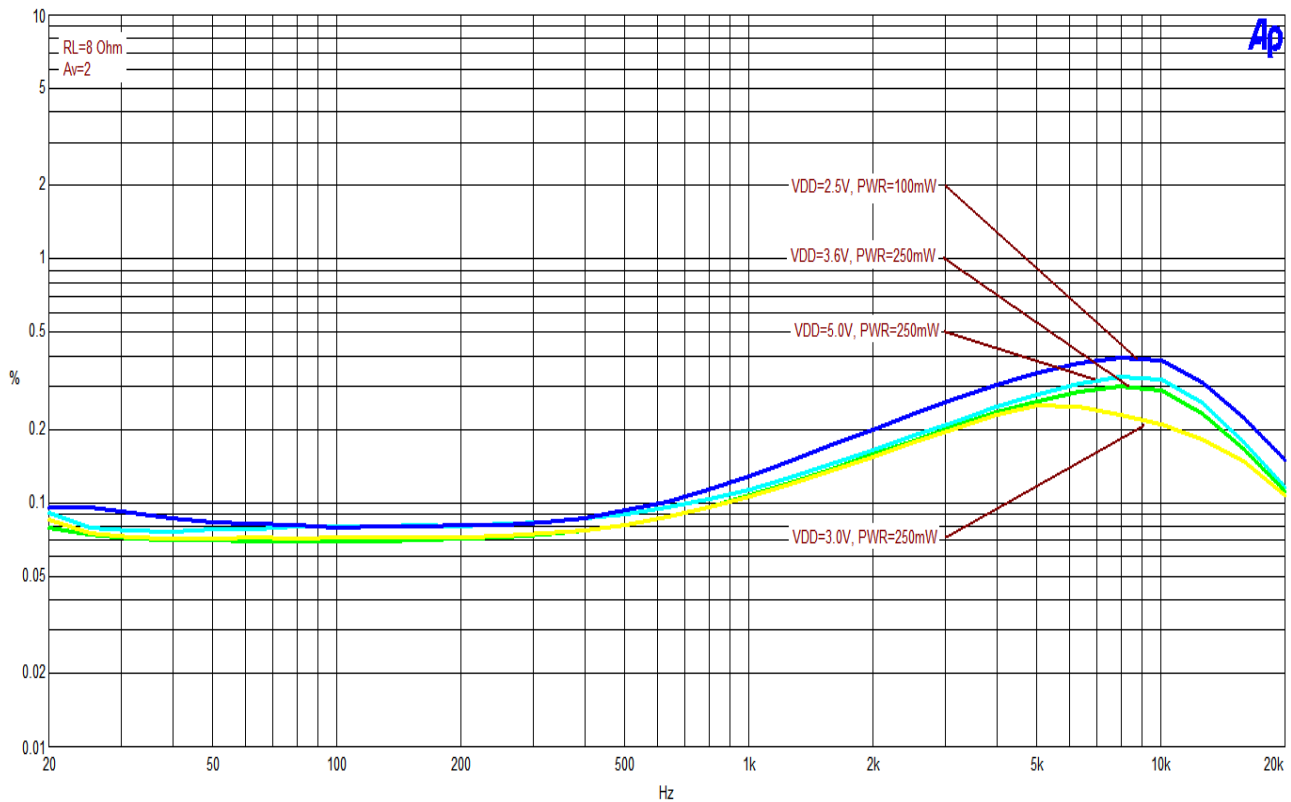

Figure 4
THD+N vs Power Out at $R_L=8\Omega$, $f=1\text{kHz}$, $A_v=2$

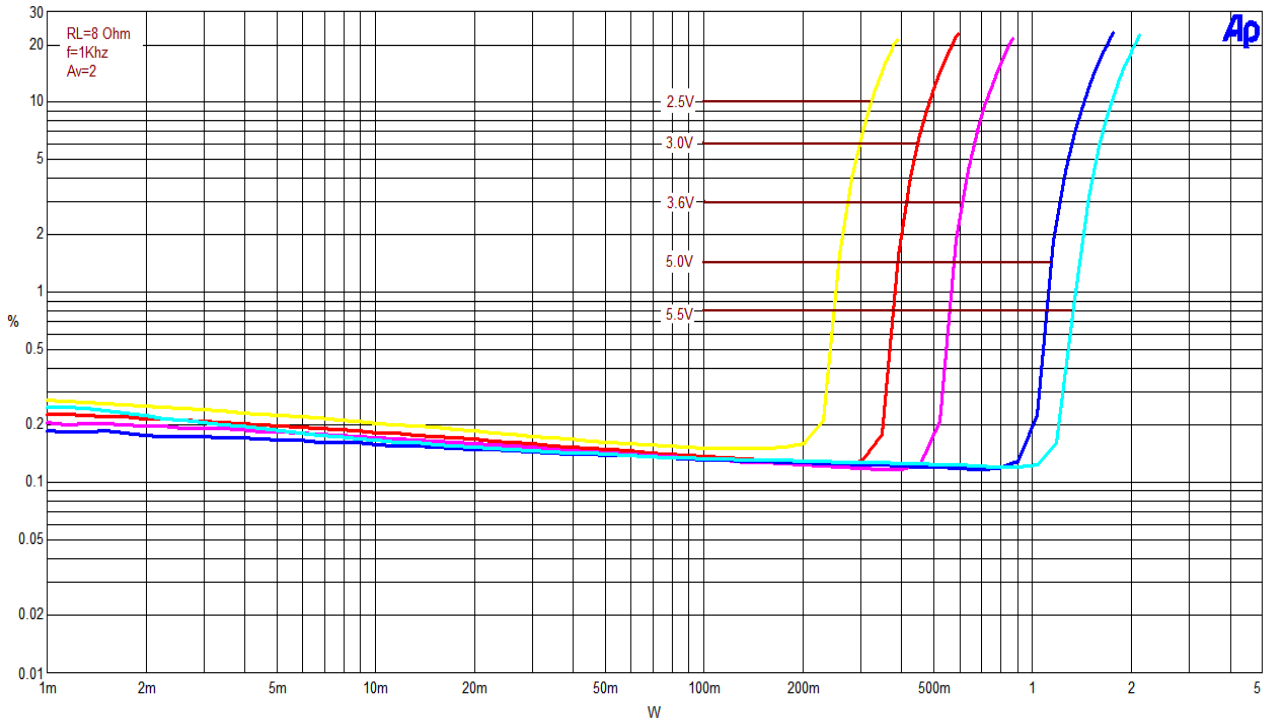
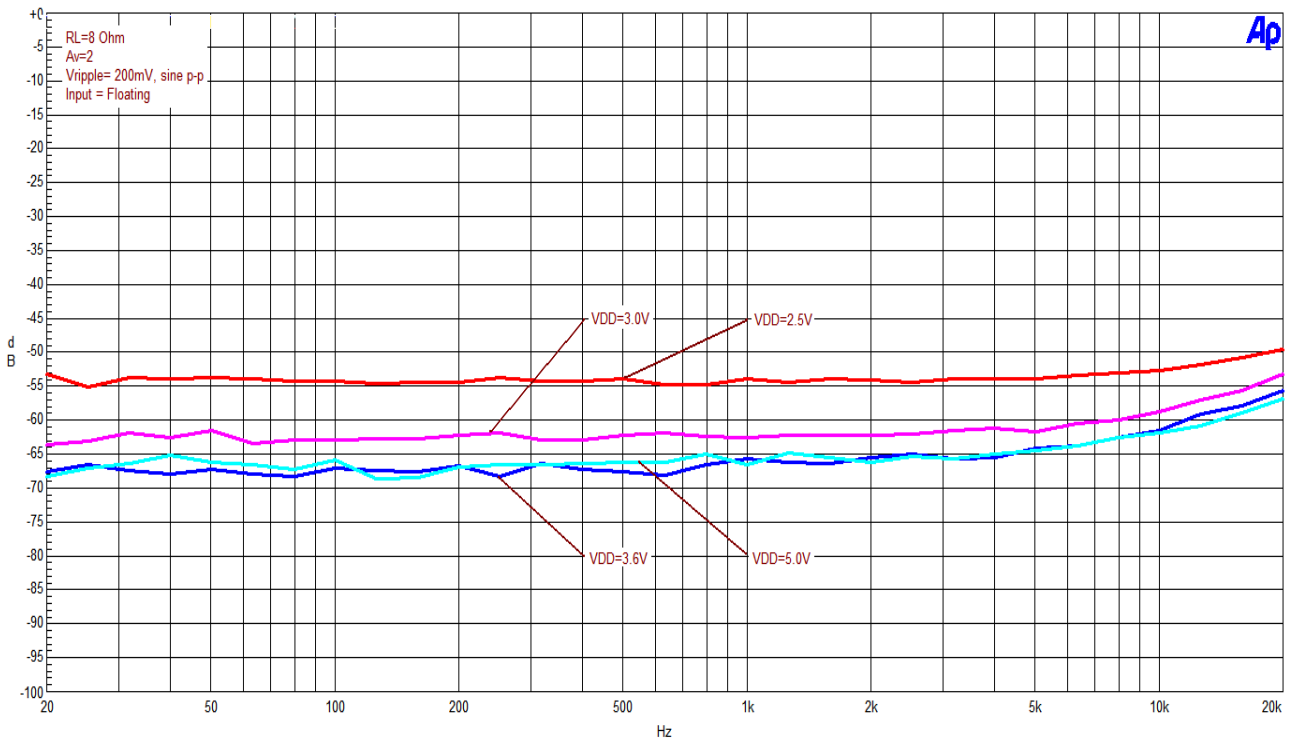

Figure 7
Power Supply Rejection Ratio (PSRR)
at $R_L=8\Omega$, $A_v=2$, Vripple = 200mVp-p, R_{IN} = Floating



APPLICATION INFORMATION

BRIDGED CONFIGURATION EXPLANATION

As shown in Figure 1, the LY8892 has two operational amplifiers internally, allowing for a few different amplifier configurations. The first amplifier's gain is externally configurable, while the second amplifier is internally fixed in a unity-gain, inverting configuration. The closed-loop gain of the first amplifier is set by selecting the ratio of R_f to R_{IN} while the second amplifier's gain is fixed by the two internal 20k Ω resistors. *Figure 1* shows that the output of amplifier one serves as the input to amplifier two which results in both amplifiers producing signals identical in magnitude, but out of phase by 180°. Consequently, the differential gain for the IC is

$$AVD = 2 \times (R_f / R_{IN}) \dots\dots\dots(1)$$

By driving the load differentially through outputs V_{o1} and V_{o2} , an amplifier configuration commonly referred to as "bridged mode" is established. Bridged mode operation is different from the classical single-ended amplifier configuration where one side of the load is connected to ground.

A bridge amplifier design has a few distinct advantages over the single-ended configuration, as it provides differential drive to the load, thus doubling output swing for a specified supply voltage. Four times the output power is possible as compared to a single-ended amplifier under the same conditions.

This increase in attainable output power assumes that the amplifier is not current limited or clipped. In order to choose an amplifier's closed-loop gain without causing excessive clipping, please refer to the Audio Power Amplifier Design section.

A bridge configuration, such as the one used in the LY8892, also creates a second advantage over single-ended amplifiers. Since the differential outputs, V_{o1} and V_{o2} , are biased at half-supply, no net DC voltage exists across the load. This eliminates the need for an output coupling capacitor which is required in a single supply, single-ended amplifier configuration. Without an output coupling capacitor, the half-supply bias across the load would result in both increased internal IC power dissipation and also possible loudspeaker damage.

INPUT CAPACITORS (C_i)

The LY8892 input capacitors and input resistors form a high-pass filter with the corner frequency, f_c , determined in equation Equation 2.

$$f_c = \frac{1}{2\pi R_i C_i} \dots\dots\dots(2)$$

Equation 3 is reconfigured to solve for the input coupling capacitance.

$$C_i = \frac{1}{2\pi R_i f_c} \dots\dots\dots(3)$$

For example

In the table 1 shows the external components. R_{in} in connect with C_{in} to create a high-pass filter.

Table 1. Typical Component Values

Reference	Description	Note
R_i	20K Ω	1% tolerance resistors
C_i	0.39 μ F	80%/-20%



$$C_i = 1 / (2\pi R_i f_c)$$

$$C_i = 1 / (2\pi \times 20K\Omega \times 20Hz) = 0.397\mu F \cdot \text{Use } 0.39\mu F$$

POWER SUPPLY BYPASSING

As with any amplifier, proper supply bypassing is critical for low noise performance and high power supply rejection. The capacitor location on both the bypass and power supply pins should be as close to the device as possible.

PACKAGE OUTLINE DIMENSION

8-PIN SOP (150 mil) PACKAGE OUTLINE DIMENSION :

