



Lyontek Inc.

LY62L20488

Rev. 1.1

2048K X 8 BIT LOW POWER CMOS SRAM

REVISION HISTORY

<u>Revision</u>	<u>Description</u>	<u>Issue Date</u>
Rev. 1.0	Initial Issue	Feb.24.2010
Rev. 1.1	Revised <u>ORDERING INFORMATION</u> in page 11	Aug.25.2010

PIN CONFIGURATION

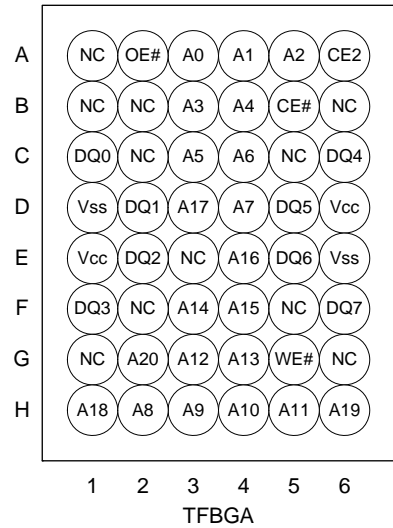
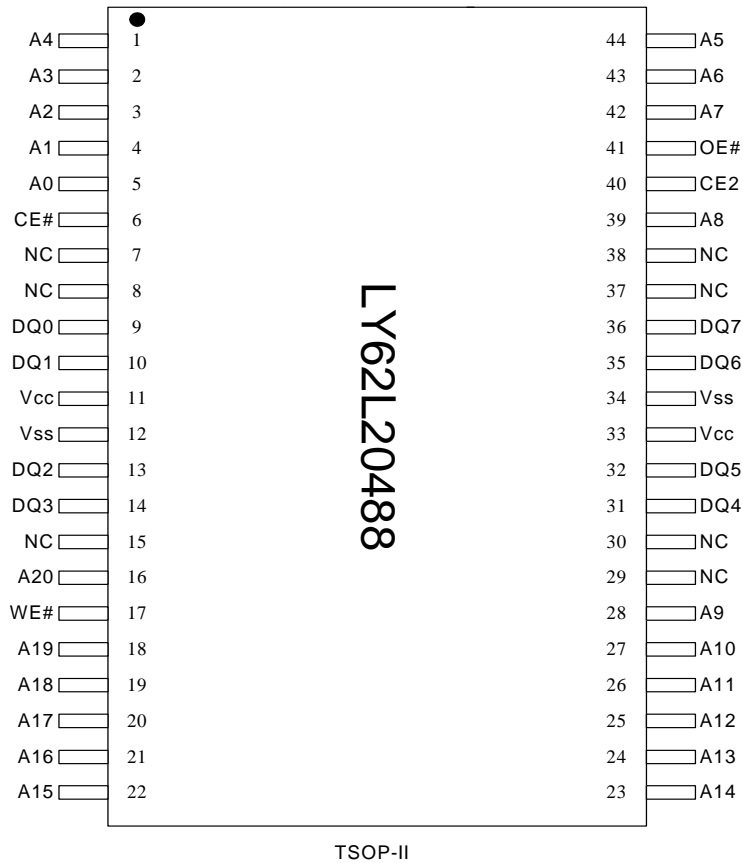



ABSOLUTE MAXIMUM RATINGS*

PARAMETER	SYMBOL	RATING	UNIT
Voltage on Vcc relative to Vss	V _{T1}	-0.5 to 4.6	V
Voltage on any other pin relative to Vss	V _{T2}	-0.5 to V _{cc} +0.5	V
Operating Temperature	T _A	0 to 70(C grade)	°C
		-20 to 80(E grade)	
		-40 to 85(I grade)	
Storage Temperature	T _{STG}	-65 to 150	°C
Power Dissipation	P _D	1	W
DC Output Current	I _{OUT}	50	mA

*Stresses greater than those listed under "Absolute Maximum Ratings" may cause permanent damage to the device. This is a stress rating only and functional operation of the device or any other conditions above those indicated in the operational sections of this specification is not implied. Exposure to the absolute maximum rating conditions for extended period may affect device reliability.

TRUTH TABLE

MODE	CE#	CE2	OE#	WE#	I/O OPERATION	SUPPLY CURRENT
Standby	H	X	X	X	High-Z	I _{SB} , I _{SB1}
	X	L	X	X	High-Z	I _{SB} , I _{SB1}
Output Disable	L	H	H	H	High-Z	I _{CC} , I _{CC1}
Read	L	H	L	H	D _{OUT}	I _{CC} , I _{CC1}
Write	L	H	X	L	D _{IN}	I _{CC} , I _{CC1}

Note: H = V_{IH}, L = V_{IL}, X = Don't care.



DC ELECTRICAL CHARACTERISTICS

PARAMETER	SYMBOL	TEST CONDITION	MIN.	TYP. ⁴	MAX.	UNIT		
Supply Voltage	V _{CC}		2.7	3.0	3.6	V		
Input High Voltage	V _{IH} ¹		2.2	-	V _{CC} +0.3	V		
Input Low Voltage	V _{IL} ²		- 0.2	-	0.6	V		
Input Leakage Current	I _{LI}	V _{CC} ≥ V _{IN} ≥ V _{SS}	- 1	-	1	μA		
Output Leakage Current	I _{LO}	V _{CC} ≥ V _{OUT} ≥ V _{SS} , Output Disabled	- 1	-	1	μA		
Output High Voltage	V _{OH}	I _{OH} = -1mA	2.2	2.7	-	V		
Output Low Voltage	V _{OL}	I _{OL} = 2mA	-	-	0.4	V		
Average Operating Power supply Current	I _{CC}	Cycle time = Min. CE# = V _{IL} and CE2 = V _{IH} I _{I/O} = 0mA Other pins at V _{IL} or V _{IH}	- 55	-	45	60	mA	
			- 70	-	30	45	mA	
	I _{CC1}	Cycle time = 1μs CE# ≤ 0.2V and CE2 ≥ V _{CC} -0.2V I _{I/O} = 0mA other pins at 0.2V or V _{CC} -0.2V	-	8	16	mA		
Standby Power Supply Current	I _{SB}	CE# = V _{IH} or CE2 = V _{IL} Other pins at V _{IL} or V _{IH}	-	0.3	2	mA		
	I _{SB1}	CE# ≥ V _{CC} -0.2V or CE2 ≤ 0.2V Other pins at 0.2V or V _{CC} -0.2V	LL	-	10	60	μA	
			LLE	-	10	80	μA	
			LLI	-	10	100	μA	
			SL ⁺⁵	25°C	-	4	6	μA
			SLE ⁺⁵		-	4	6	μA
			SLI ⁺⁵	40°C	-	4	6	μA
			SL		-	4	30	μA
			SLE		-	4	30	μA
SLI	-	4	40	μA				

Notes:

- V_{IH}(max) = V_{CC} + 3.0V for pulse width less than 10ns.
- V_{IL}(min) = V_{SS} - 3.0V for pulse width less than 10ns.
- Over/Undershoot specifications are characterized, not 100% tested.
- Typical values are included for reference only and are not guaranteed or tested.
Typical values are measured at V_{CC} = V_{CC}(TYP.) and T_A = 25°C
- This parameter is measured at V_{CC} = 3.0V

**CAPACITANCE (T_A = 25°C, f = 1.0MHz)**

PARAMETER	SYMBOL	MIN.	MAX	UNIT
Input Capacitance	C _{IN}	-	6	pF
Input/Output Capacitance	C _{I/O}	-	8	pF

Note : These parameters are guaranteed by device characterization, but not production tested.

AC TEST CONDITIONS

Input Pulse Levels	0.2V to V _{CC} - 0.2V
Input Rise and Fall Times	3ns
Input and Output Timing Reference Levels	1.5V
Output Load	C _L = 30pF + 1TTL, I _{OH} /I _{OL} = -1mA/2mA

AC ELECTRICAL CHARACTERISTICS**(1) READ CYCLE**

PARAMETER	SYM.	LY62L20488-55		LY62L20488-70		UNIT
		MIN.	MAX.	MIN.	MAX.	
Read Cycle Time	t _{RC}	55	-	70	-	ns
Address Access Time	t _{AA}	-	55	-	70	ns
Chip Enable Access Time	t _{ACE}	-	55	-	70	ns
Output Enable Access Time	t _{OE}	-	30	-	35	ns
Chip Enable to Output in Low-Z	t _{CLZ} *	10	-	10	-	ns
Output Enable to Output in Low-Z	t _{OLZ} *	5	-	5	-	ns
Chip Disable to Output in High-Z	t _{CHZ} *	-	20	-	25	ns
Output Disable to Output in High-Z	t _{OHZ} *	-	20	-	25	ns
Output Hold from Address Change	t _{OH}	10	-	10	-	ns

(2) WRITE CYCLE

PARAMETER	SYM.	LY62L20488-55		LY62L20488-70		UNIT
		MIN.	MAX.	MIN.	MAX.	
Write Cycle Time	t _{WC}	55	-	70	-	ns
Address Valid to End of Write	t _{AW}	50	-	60	-	ns
Chip Enable to End of Write	t _{CW}	50	-	60	-	ns
Address Set-up Time	t _{AS}	0	-	0	-	ns
Write Pulse Width	t _{WP}	45	-	55	-	ns
Write Recovery Time	t _{WR}	0	-	0	-	ns
Data to Write Time Overlap	t _{DW}	25	-	30	-	ns
Data Hold from End of Write Time	t _{DH}	0	-	0	-	ns
Output Active from End of Write	t _{OW} *	5	-	5	-	ns
Write to Output in High-Z	t _{WHZ} *	-	20	-	25	ns

*These parameters are guaranteed by device characterization, but not production tested.

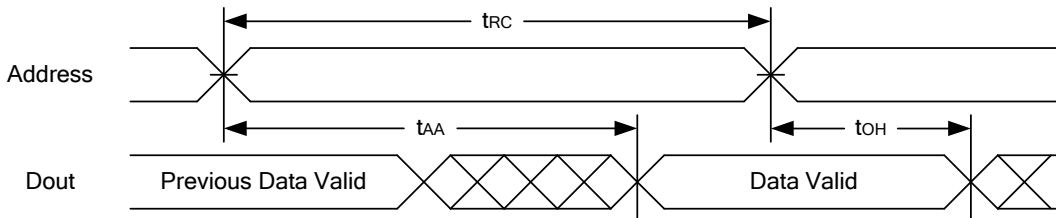
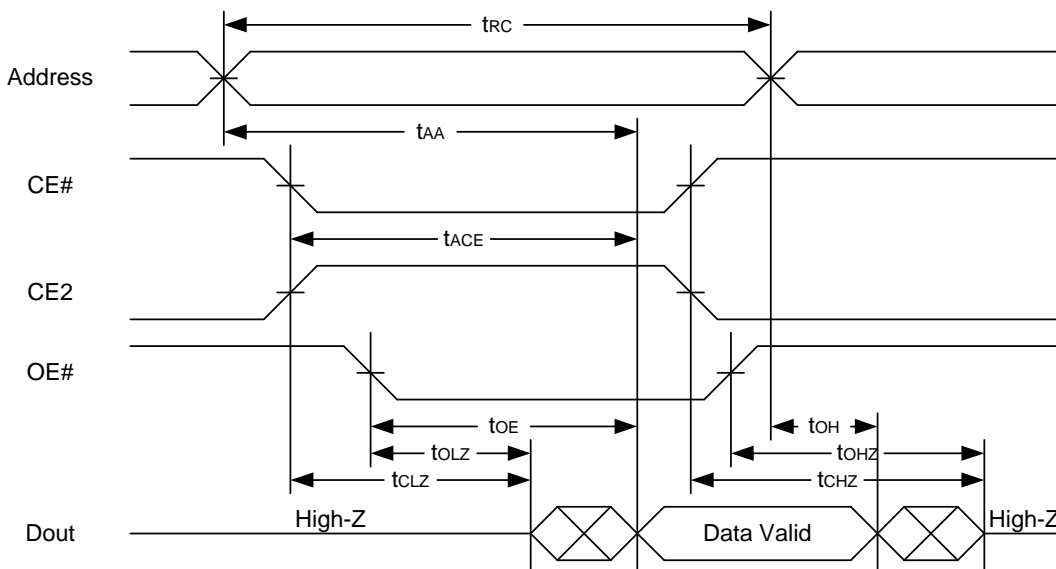
TIMING WAVEFORMS
READ CYCLE 1 (Address Controlled) (1,2)

READ CYCLE 2 (CE# and CE2 and OE# Controlled) (1,3,4,5)

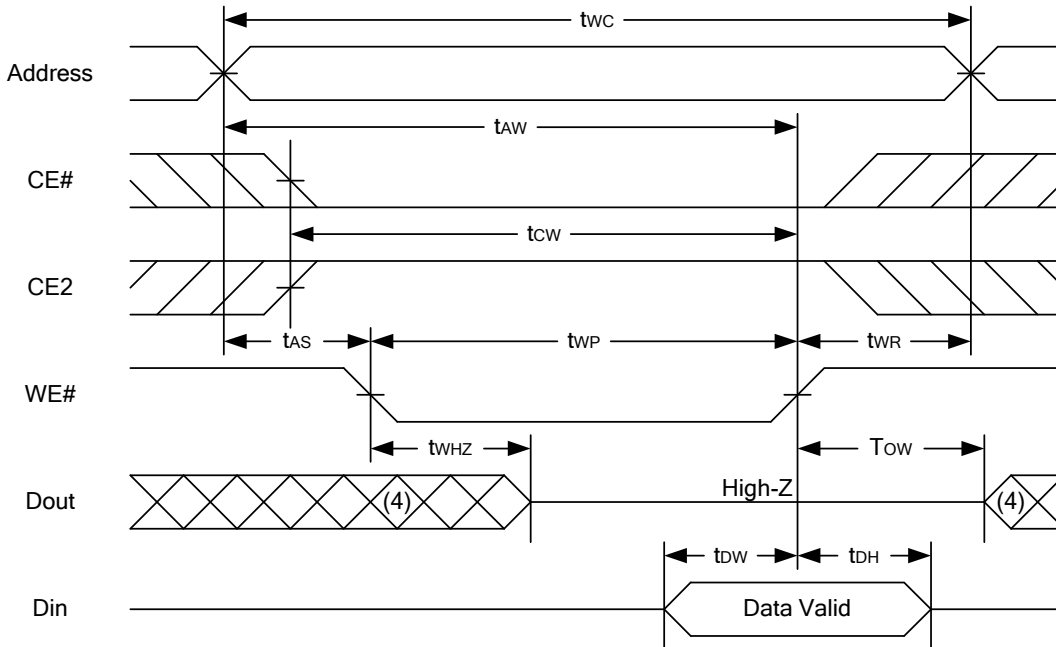
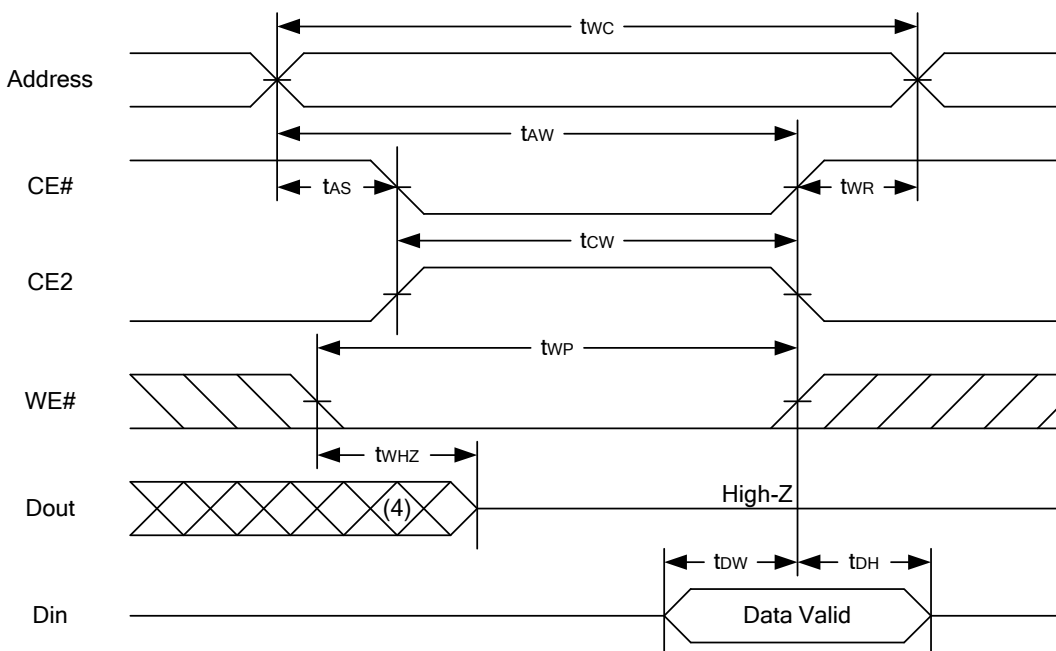
Notes :

1. WE# is high for read cycle.
2. Device is continuously selected OE# = low, CE# = low, CE2 = high.
3. Address must be valid prior to or coincident with CE# = low, CE2 = high; otherwise tAA is the limiting parameter.
4. tCLZ, tOLZ, tCHZ and tOHZ are specified with CL = 5pF. Transition is measured ±500mV from steady state.
5. At any given temperature and voltage condition, tCHZ is less than tCLZ, tOHZ is less than tOLZ.

WRITE CYCLE 1 (WE# Controlled) (1,2,3,5,6)

WRITE CYCLE 2 (CE# and CE2 Controlled) (1,2,5,6)

Notes :

1. WE#, CE# must be high or CE2 must be low during all address transitions.
2. A write occurs during the overlap of a low CE#, high CE2, low WE#.
3. During a WE#-controlled write cycle with OE# low, tWP must be greater than tWHZ + tDW to allow the drivers to turn off and data to be placed on the bus.
4. During this period, I/O pins are in the output state, and input signals must not be applied.
5. If the CE# low transition and CE2 high transition occurs simultaneously with or after WE# low transition, the outputs remain in a high impedance state.
6. tOW and tWHZ are specified with CL = 5pF. Transition is measured ±500mV from steady state.

DATA RETENTION CHARACTERISTICS

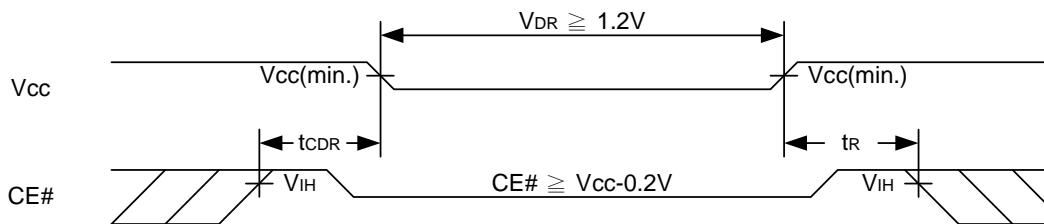
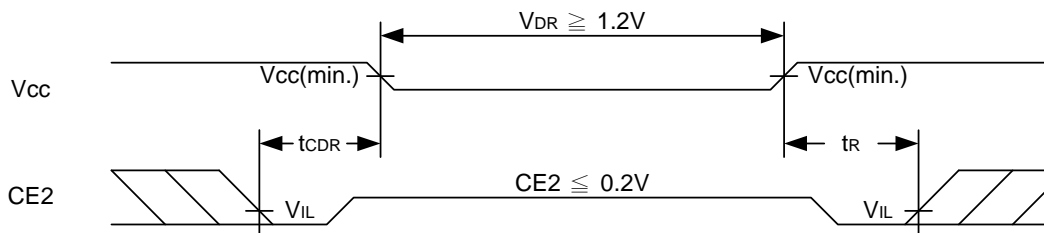
PARAMETER	SYMBOL	TEST CONDITION	MIN.	TYP.	MAX.	UNIT		
V _{CC} for Data Retention	V _{DR}	CE# ≥ V _{CC} - 0.2V or CE2 ≤ 0.2V	1.2	-	3.6	V		
Data Retention Current	I _{DR}	V _{CC} = 1.2V CE# ≥ V _{CC} -0.2V or CE2 ≤ 0.2V other pins at 0.2V or V _{CC} -0.2V	LL	-	4	50	μA	
			LLE	-	4	60	μA	
			LLI	-	4	80	μA	
			SL	25°C	-	2.5	5	μA
			SLE	40°C	-	2.5	5	μA
			SLI	40°C	-	2.5	5	μA
			SL/SLE	-	-	2.5	30	μA
SLI	-	-	2.5	40	μA			
Chip Disable to Data Retention Time	t _{CDR}	See Data Retention Waveforms (below)	0	-	-	ns		
Recovery Time	t _R		t _{RC} *	-	-	ns		

 t_{RC}* = Read Cycle Time

DATA RETENTION WAVEFORM
Low V_{CC} Data Retention Waveform (1) (CE# controlled)

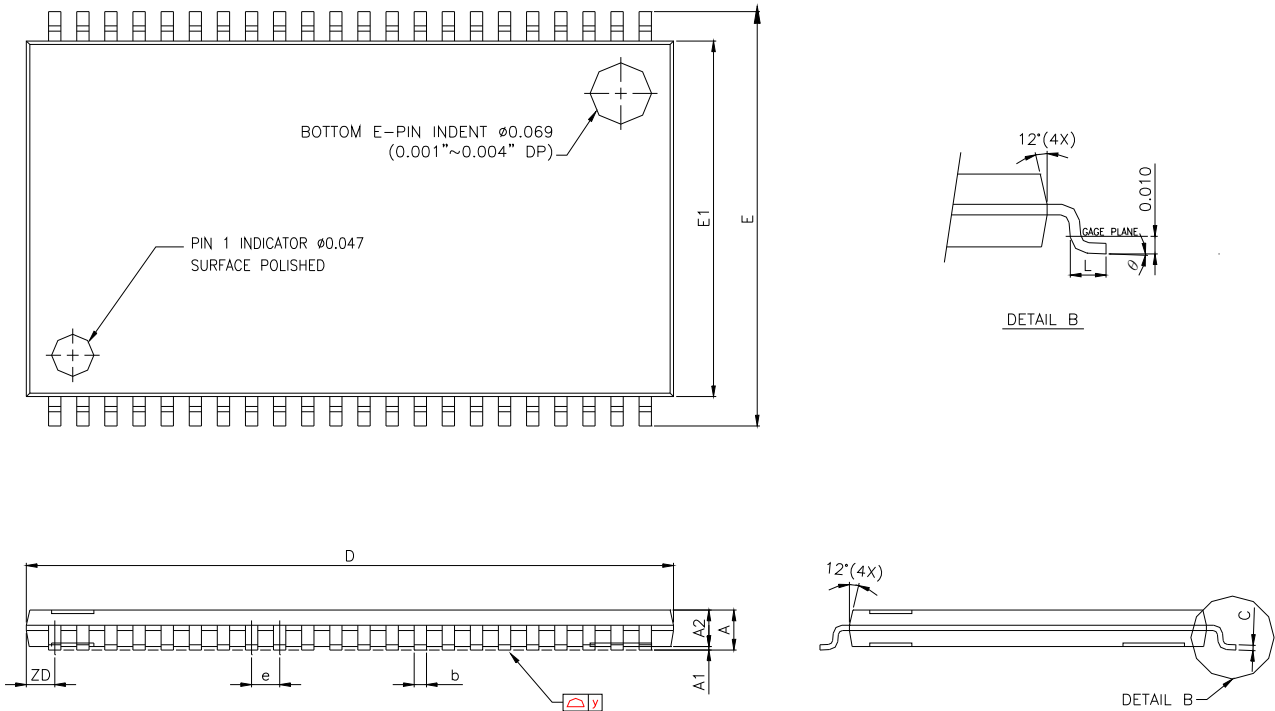
Low V_{CC} Data Retention Waveform (2) (CE2 controlled)

PACKAGE OUTLINE DIMENSION
44-pin 400mil TSOP-II Package Outline Dimension

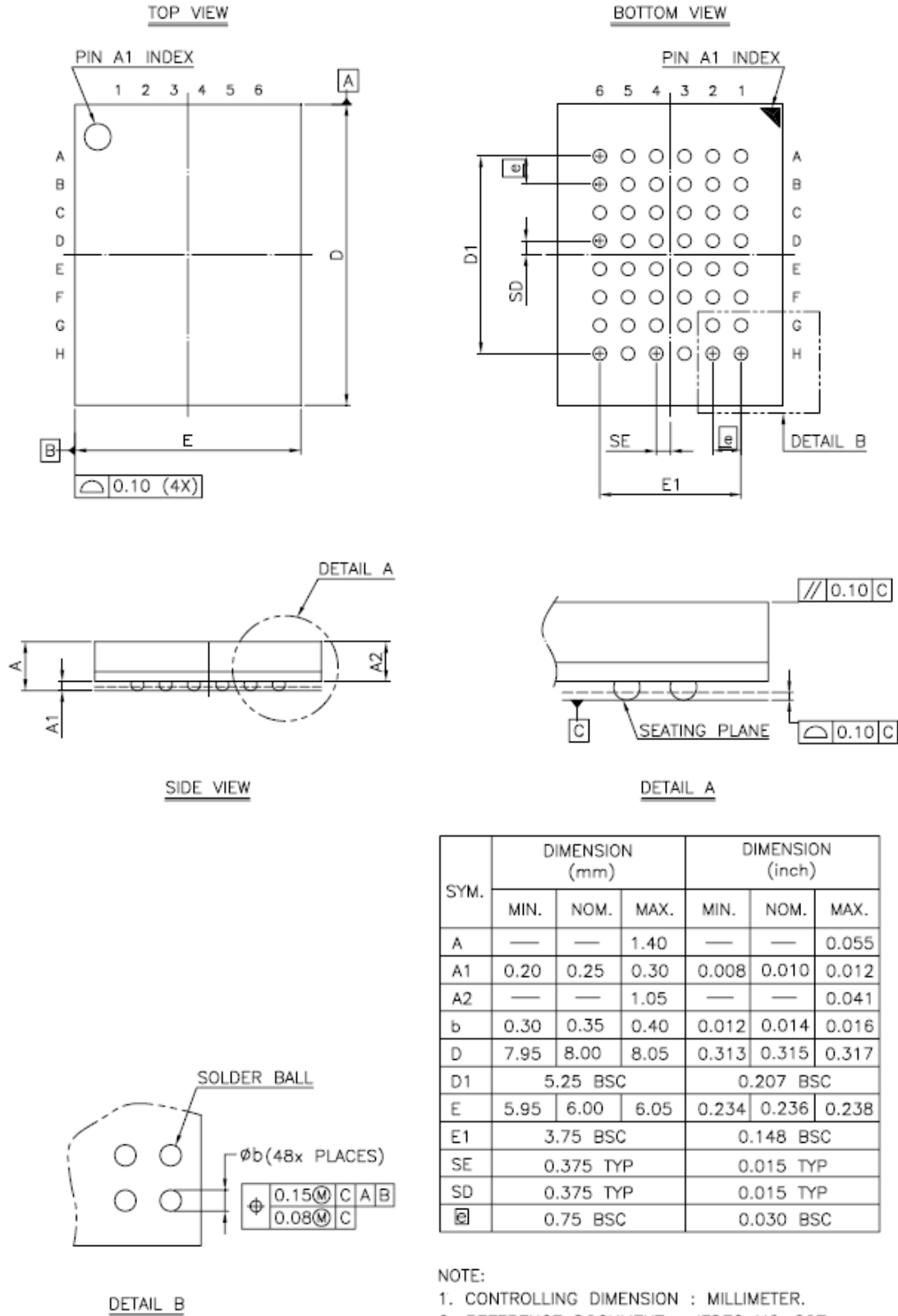
SYMBOLS	DIMENSIONS IN MILLMETERS			DIMENSIONS IN MILS		
	MIN.	NOM.	MAX.	MIN.	NOM.	MAX.
A	-	-	1.20	-	-	47.2
A1	0.05	0.10	0.15	2.0	3.9	5.9
A2	0.95	1.00	1.05	37.4	39.4	41.3
b	0.30	-	0.45	11.8	-	17.7
c	0.12	-	0.21	4.7	-	8.3
D	18.212	18.415	18.618	717	725	733
E	11.506	11.760	12.014	453	463	473
E1	9.957	10.160	10.363	392	400	408
e	-	0.800	-	-	31.5	-
L	0.40	0.50	0.60	15.7	19.7	23.6
ZD	-	0.805	-	-	31.7	-
y	-	-	0.076	-	-	3
θ	0°	3°	6°	0°	3°	6°

48-ball 6mm x 8mm TFBGA Package Outline Dimension

NOTE:

1. CONTROLLING DIMENSION : MILLIMETER.
2. REFERENCE DOCUMENT : JEDEC MO-207.



ORDERING INFORMATION

LY62L20488 U V - WW XX Y Z

Z : Packing Type

Blank : Tube or Tray
Tray : 44-pin 400 mil TSOP-II
48-ball 6 mm x 8 mm TFBGA
T : Tape Reel

Y : Temperature Range

Blank : (Commercial) 0°C ~ 70°C
E : (Extended) -20°C ~ +80°C
I : (Industrial) -40°C ~ +85°C

XX : Power Type

LL : Ultra Low Power
SL : Special Ultra Low Power

WW : Access Time(Speed)

V : Lead Information

L : Green Package

U : Package Type

M : 44-pin 400 mil TSOP-II
G : 48-ball 6 mm x 8 mm TFBGA



®

Lyontek Inc.

LY62L20488

Rev. 1.1

2048K X 8 BIT LOW POWER CMOS SRAM

THIS PAGE IS LEFT BLANK INTENTIONALLY.