



REVISION HISTORY

<u>Revision</u>	<u>Description</u>	<u>Issue Date</u>
Rev. 1.0	Initial Issue	Apr.12.2007
Rev. 1.1	Revised 48-ball 6mm x 8mm TFBGA Package Outline Dimension	May.28.2007
Rev. 1.2	Added I _{SB} Spec.	Feb.1.2008
Rev. 1.3	Added SL Spec.	Jul.2.2008
Rev. 1.4	Added I _{SB1} /I _{DR} values when T _A = 25°C and T _A = 40°C Revised <u>FEATURES & ORDERING INFORMATION</u> <u>Lead free and green package available to Green package available</u> Added packing type in <u>ORDERING INFORMATION</u> Deleted T _{SOLDER} in <u>ABSOLUTE MAXIMUM RATINGS</u>	Mar.30.2009
Rev. 1.5	Revised <u>ORDERING INFORMATION</u> in page 11	Aug.30.2010
Rev. 1.6	Deleted E grade	Apr.12.2011

FEATURES

- Fast access time : 55/70ns
- Low power consumption:
 Operating current : 30/20mA (TYP.)
 Standby current : 5 μ A (TYP.) LL-version
 1.5 μ A (TYP.) SL-version
- Single 2.7V ~ 3.6V power supply
- All inputs and outputs TTL compatible
- Fully static operation
- Tri-state output
- Data byte control : LB# (DQ0 ~ DQ7)
 UB# (DQ8 ~ DQ15)
- Data retention voltage : 1.2V (MIN.)
- **Green package available**
- Package : 48-pin 12mm x 20mm TSOP-I
 48-ball 6mm x 8mm TFBGA

PRODUCT FAMILY

Product Family	Operating Temperature	Vcc Range	Speed	Power Dissipation	
				Standby(I_{SB1} , TYP.)	Operating(I_{CC} , TYP.)
LY62L51316	0 ~ 70°C	2.7 ~ 3.6V	55/70ns	5 μ A(LL)/1.5 μ A(SL)	30/20mA
LY62L51316(I)	-40 ~ 85°C	2.7 ~ 3.6V	55/70ns	5 μ A(LL)/1.5 μ A(SL)	30/20mA

GENERAL DESCRIPTION

The LY62L51316 is a 8,388,608-bit low power CMOS static random access memory organized as 524,288 words by 16 bits. It is fabricated using very high performance, high reliability CMOS technology. Its standby current is stable within the range of operating temperature.

The LY62L51316 is well designed for low power application, and particularly well suited for battery back-up nonvolatile memory application.

The LY62L51316 operates from a single power supply of 2.7V ~ 3.6V and all inputs and outputs are fully TTL compatible

FUNCTIONAL BLOCK DIAGRAM

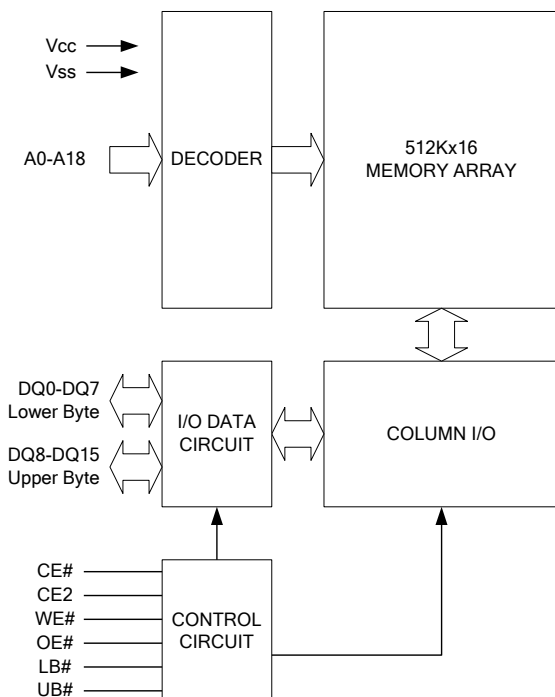

PIN DESCRIPTION

SYMBOL	DESCRIPTION
A0 - A18	Address Inputs
DQ0 - DQ15	Data Inputs/Outputs
CE#, CE2	Chip Enable Input
WE#	Write Enable Input
OE#	Output Enable Input
LB#	Lower Byte Control
UB#	Upper Byte Control
Vcc	Power Supply
Vss	Ground

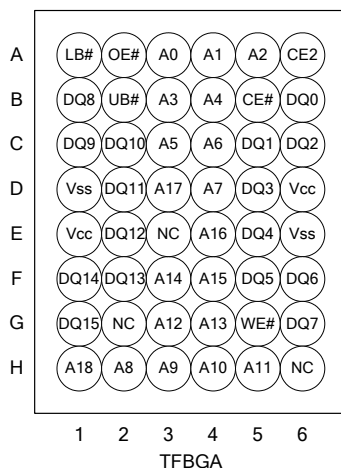
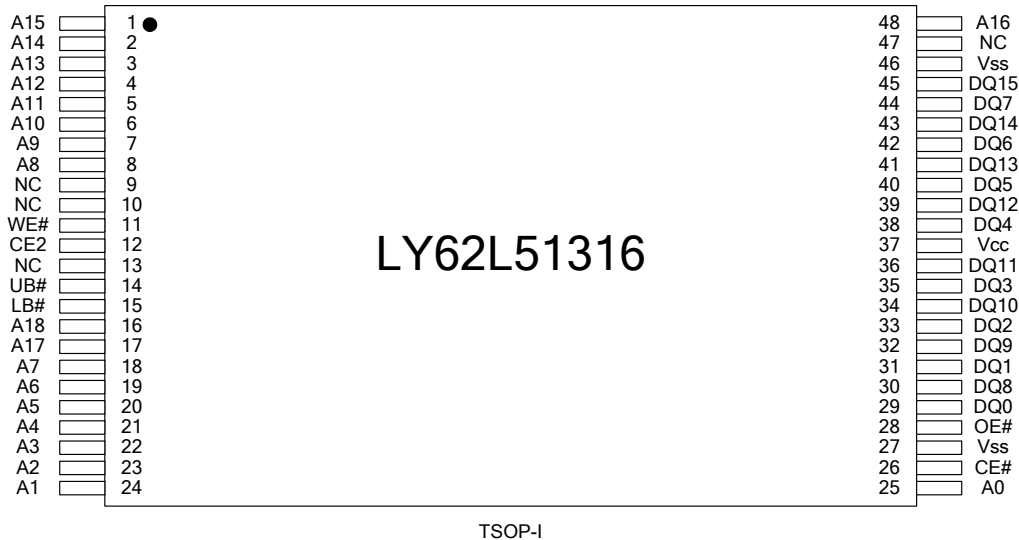
PIN CONFIGURATION

ABSOLUTE MAXIMUM RATINGS*

PARAMETER	SYMBOL	RATING	UNIT
Voltage on Vcc relative to Vss	V _{T1}	-0.5 to 4.6	V
Voltage on any other pin relative to Vss	V _{T2}	-0.5 to V _{cc} +0.5	V
Operating Temperature	T _A	0 to 70(C grade)	°C
		-40 to 85(I grade)	
Storage Temperature	T _{STG}	-65 to 150	°C
Power Dissipation	P _D	1	W
DC Output Current	I _{OUT}	50	mA

*Stresses greater than those listed under "Absolute Maximum Ratings" may cause permanent damage to the device. This is a stress rating only and functional operation of the device or any other conditions above those indicated in the operational sections of this specification is not implied. Exposure to the absolute maximum rating conditions for extended period may affect device reliability.



TRUTH TABLE

MODE	CE#	CE2	OE#	WE#	LB#	UB#	I/O OPERATION		SUPPLY CURRENT
							DQ0-DQ7	DQ8-DQ15	
Standby	H	X	X	X	X	X	High - Z	High - Z	I _{SB} , I _{SB1}
	X	L	X	X	X	X	High - Z	High - Z	
	X	X	X	X	H	H	High - Z	High - Z	
Output Disable	L	H	H	H	L	X	High - Z	High - Z	I _{CC} , I _{CC1}
	L	H	H	H	X	L	High - Z	High - Z	
Read	L	H	L	H	L	H	D _{OUT}	High - Z	I _{CC} , I _{CC1}
	L	H	L	H	H	L	High - Z	D _{OUT}	
	L	H	L	H	L	L	D _{OUT}	D _{OUT}	
Write	L	H	X	L	L	H	D _{IN}	High - Z	I _{CC} , I _{CC1}
	L	H	X	L	H	L	High - Z	D _{IN}	
	L	H	X	L	L	L	D _{IN}	D _{IN}	

Note: H = V_{IH}, L = V_{IL}, X = Don't care.

DC ELECTRICAL CHARACTERISTICS

PARAMETER	SYMBOL	TEST CONDITION	MIN.	TYP. ⁴	MAX.	UNIT		
Supply Voltage	V _{CC}		2.7	3.0	3.6	V		
Input High Voltage	V _{IH} ¹		2.2	-	V _{CC} +0.3	V		
Input Low Voltage	V _{IL} ²		-0.2	-	0.6	V		
Input Leakage Current	I _{LI}	V _{CC} ≥ V _{IN} ≥ V _{SS}	-1	-	1	μA		
Output Leakage Current	I _{LO}	V _{CC} ≥ V _{OUT} ≥ V _{SS} , Output Disabled	-1	-	1	μA		
Output High Voltage	V _{OH}	I _{OH} = -1mA	2.2	2.7	-	V		
Output Low Voltage	V _{OL}	I _{OL} = 2mA	-	-	0.4	V		
Average Operating Power supply Current	I _{CC}	Cycle time = Min. CE# = V _{IL} and CE2 = V _{IH} I _{I/O} = 0mA Other pins at V _{IL} or V _{IH}	-55	-	30	40	mA	
			-70	-	20	30	mA	
	I _{CC1}	Cycle time = 1μs CE# ≤ 0.2V and CE2 ≥ V _{CC} -0.2V I _{I/O} = 0mA Other pins at 0.2V or V _{CC} -0.2V	-	4	8	mA		
Standby Power Supply Current	I _{SB}	CE# = V _{IH} or CE2 = V _{IL} Other pins at V _{IL} or V _{IH}	-	0.15	1	mA		
			I _{SB1}	CE# ≥ V _{CC} -0.2V or CE2 ≤ 0.2V Other pins at 0.2V or V _{CC} -0.2V	LL	-	5	30
	LLI	-			5	50	μA	
	SL ^{*5}	25°C			-	1.5	5	μA
	SLI ^{*5}	40°C			-	1.5	5	μA
	SL	-	1.5	15	μA			
SLI	-	1.5	20	μA				

Notes:

- V_{IH}(max) = V_{CC} + 3.0V for pulse width less than 10ns.
- V_{IL}(min) = V_{SS} - 3.0V for pulse width less than 10ns.
- Over/Undershoot specifications are characterized, not 100% tested.
- Typical values are included for reference only and are not guaranteed or tested.
Typical values are measured at V_{CC} = V_{CC}(TYP.) and T_A = 25°C
- This parameter is measured at V_{CC} = 3.0V



CAPACITANCE (TA = 25°C, f = 1.0MHz)

PARAMETER	SYMBOL	MIN.	MAX	UNIT
Input Capacitance	C _{IN}	-	6	pF
Input/Output Capacitance	C _{I/O}	-	8	pF

Note : These parameters are guaranteed by device characterization, but not production tested.

AC TEST CONDITIONS

Input Pulse Levels	0.2V to V _{CC} - 0.2V
Input Rise and Fall Times	3ns
Input and Output Timing Reference Levels	1.5V
Output Load	C _L = 30pF + 1TTL, I _{OH} /I _{OL} = -1mA/2mA

AC ELECTRICAL CHARACTERISTICS

(1) READ CYCLE

PARAMETER	SYM.	LY62L51316-55		LY62L51316-70		UNIT
		MIN.	MAX.	MIN.	MAX.	
Read Cycle Time	t _{RC}	55	-	70	-	ns
Address Access Time	t _{AA}	-	55	-	70	ns
Chip Enable Access Time	t _{ACE}	-	55	-	70	ns
Output Enable Access Time	t _{OE}	-	30	-	35	ns
Chip Enable to Output in Low-Z	t _{CLZ} *	10	-	10	-	ns
Output Enable to Output in Low-Z	t _{OLZ} *	5	-	5	-	ns
Chip Disable to Output in High-Z	t _{CHZ} *	-	20	-	25	ns
Output Disable to Output in High-Z	t _{OHZ} *	-	20	-	25	ns
Output Hold from Address Change	t _{OH}	10	-	10	-	ns
LB#, UB# Access Time	t _{BA}	-	55	-	70	ns
LB#, UB# to High-Z Output	t _{BHZ} *	-	25	-	30	ns
LB#, UB# to Low-Z Output	t _{BLZ} *	10	-	10	-	ns

(2) WRITE CYCLE

PARAMETER	SYM.	LY62L51316-55		LY62L51316-70		UNIT
		MIN.	MAX.	MIN.	MAX.	
Write Cycle Time	t _{WC}	55	-	70	-	ns
Address Valid to End of Write	t _{AW}	50	-	60	-	ns
Chip Enable to End of Write	t _{CW}	50	-	60	-	ns
Address Set-up Time	t _{AS}	0	-	0	-	ns
Write Pulse Width	t _{WP}	45	-	55	-	ns
Write Recovery Time	t _{WR}	0	-	0	-	ns
Data to Write Time Overlap	t _{DW}	25	-	30	-	ns
Data Hold from End of Write Time	t _{DH}	0	-	0	-	ns
Output Active from End of Write	t _{OW} *	5	-	5	-	ns
Write to Output in High-Z	t _{WHZ} *	-	20	-	25	ns
LB#, UB# Valid to End of Write	t _{BW}	45	-	60	-	ns

*These parameters are guaranteed by device characterization, but not production tested.

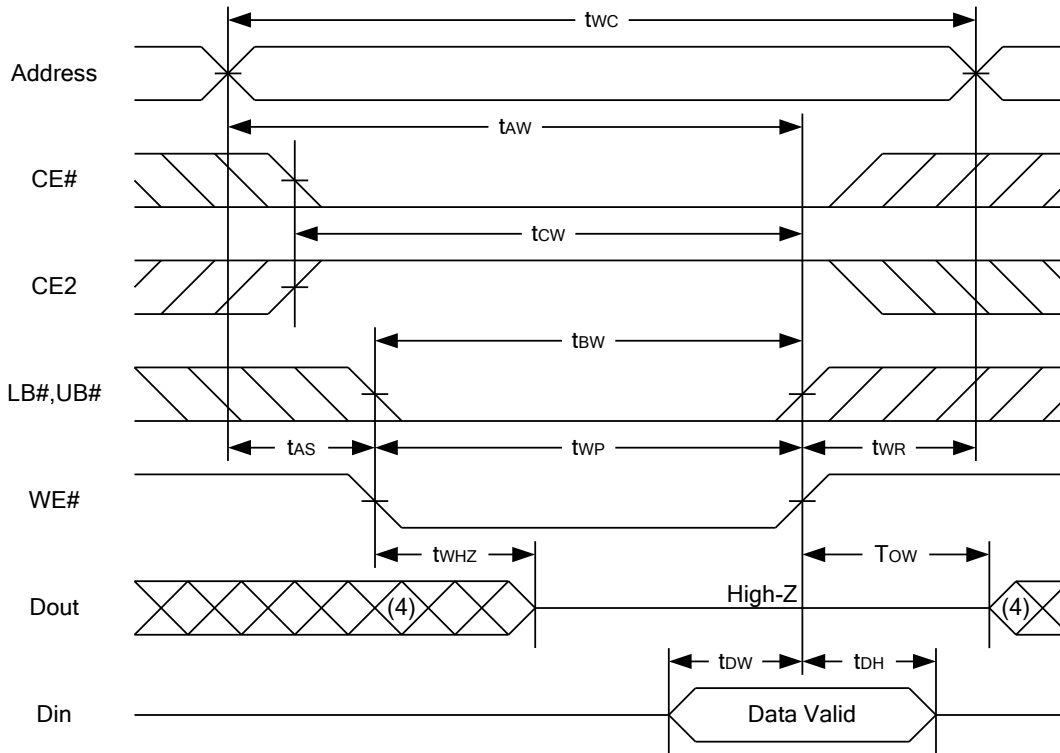
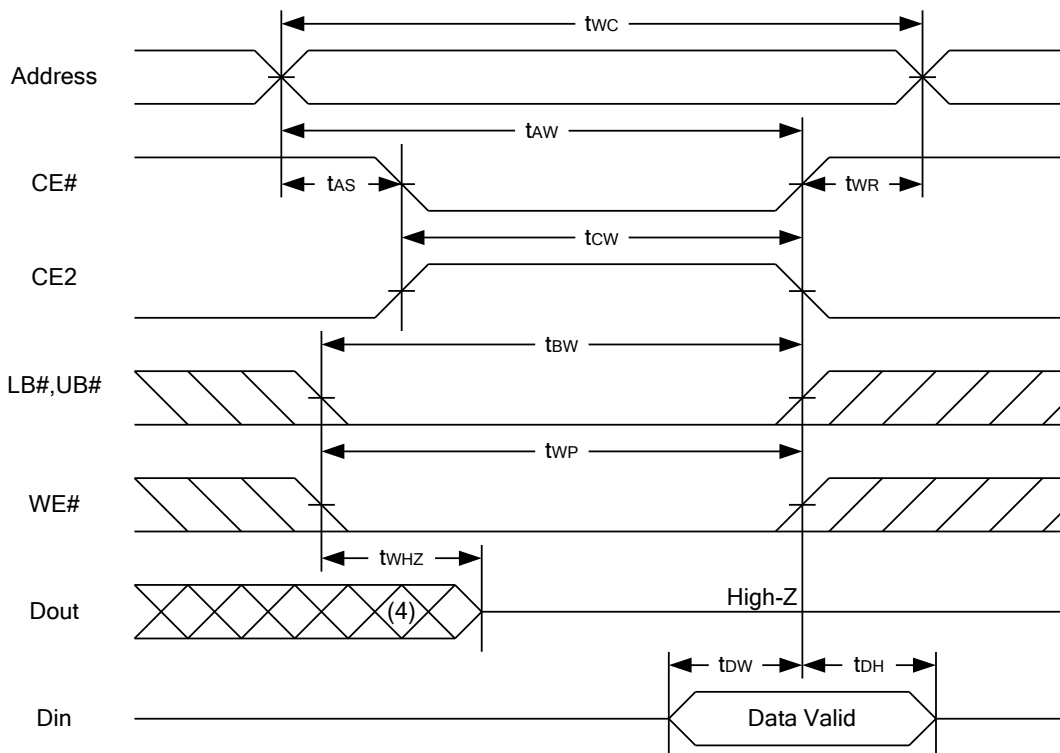
WRITE CYCLE 1 (WE# Controlled) (1,2,3,5,6)

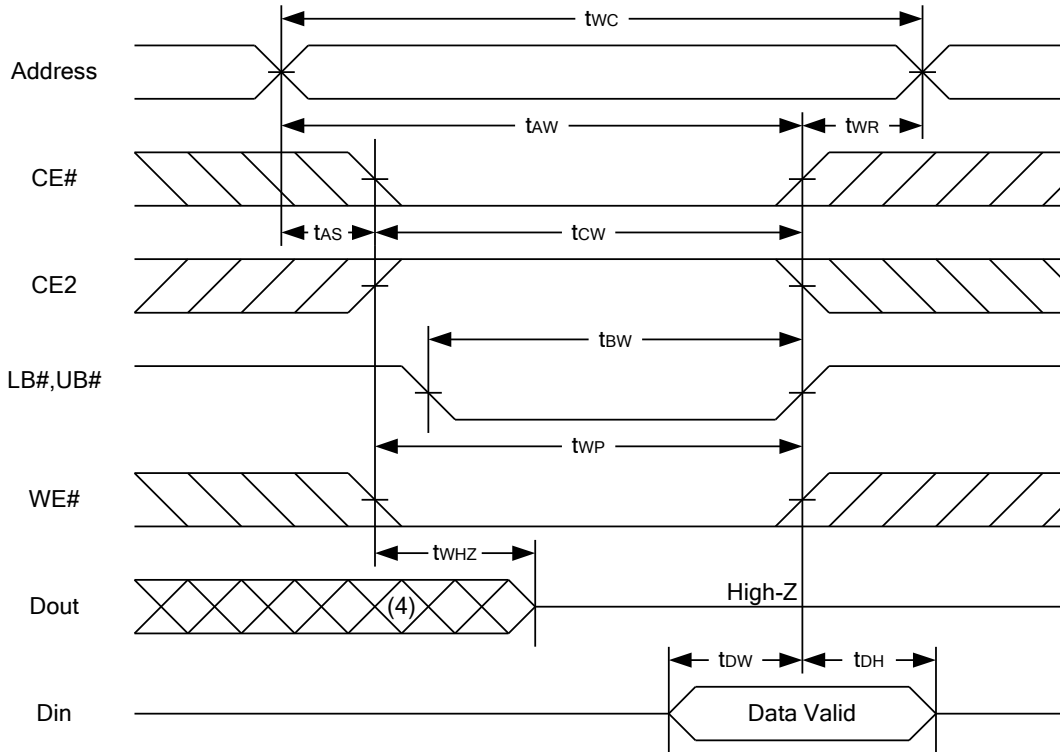
WRITE CYCLE 2 (CE# and CE2 Controlled) (1,2,5,6)

WRITE CYCLE 3 (LB#,UB# Controlled) (1,2,5,6)

Notes :

1. WE#, CE#, LB#, UB# must be high or CE2 must be low during all address transitions.
2. A write occurs during the overlap of a low CE#, high CE2, low WE#, LB# or UB# = low.
3. During a WE# controlled write cycle with OE# low, t_{WP} must be greater than $t_{WHZ} + t_{DW}$ to allow the drivers to turn off and data to be placed on the bus.
4. During this period, I/O pins are in the output state, and input signals must not be applied.
5. If the CE#, LB#, UB# low transition and CE2 high transition occurs simultaneously with or after WE# low transition, the outputs remain in a high impedance state.
6. t_{ow} and t_{whz} are specified with $C_L = 5pF$. Transition is measured $\pm 500mV$ from steady state.

DATA RETENTION CHARACTERISTICS

PARAMETER	SYMBOL	TEST CONDITION	MIN.	TYP.	MAX.	UNIT	
V _{CC} for Data Retention	V _{DR}	CE# ≥ V _{CC} - 0.2V or CE2 ≤ 0.2V	1.2	-	3.6	V	
Data Retention Current	I _{DR}	V _{CC} = 1.2V CE# ≥ V _{CC} -0.2V or CE2 ≤ 0.2V Other pins at 0.2V or V _{CC} -0.2V	LL	-	2	25	μA
			LLI	-	2	40	μA
			SL 25°C	-	1	3	μA
			SLI 40°C	-	1	3	μA
			SL	-	1	15	μA
			SLI	-	1	20	μA
Chip Disable to Data Retention Time	t _{CDR}	See Data Retention Waveforms (below)	0	-	-	ns	
Recovery Time	t _r		t _{RC} *	-	-	ns	

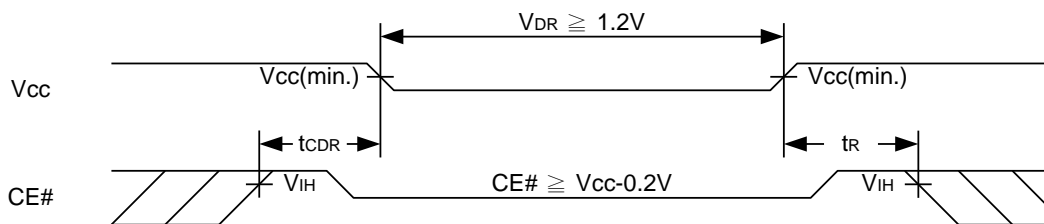
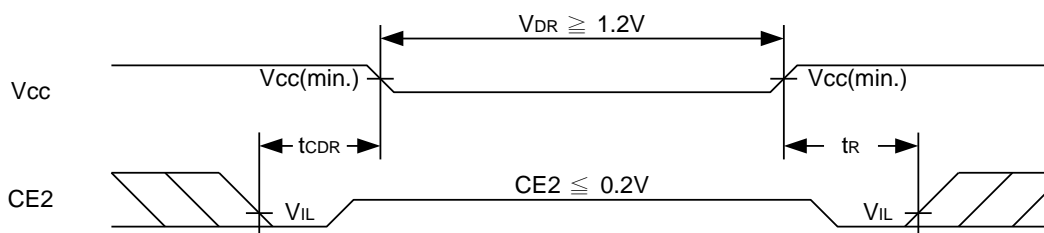
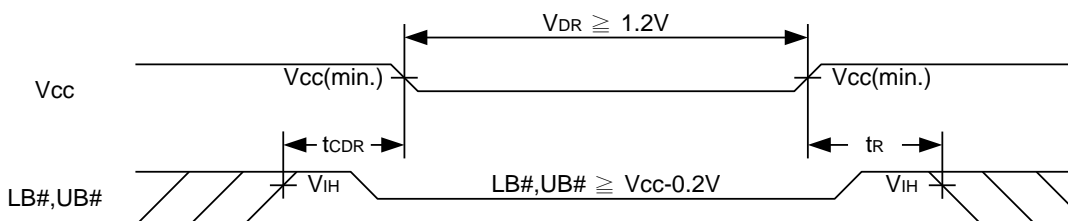
 t_{RC}* = Read Cycle Time

DATA RETENTION WAVEFORM
Low V_{CC} Data Retention Waveform (1) (CE# controlled)

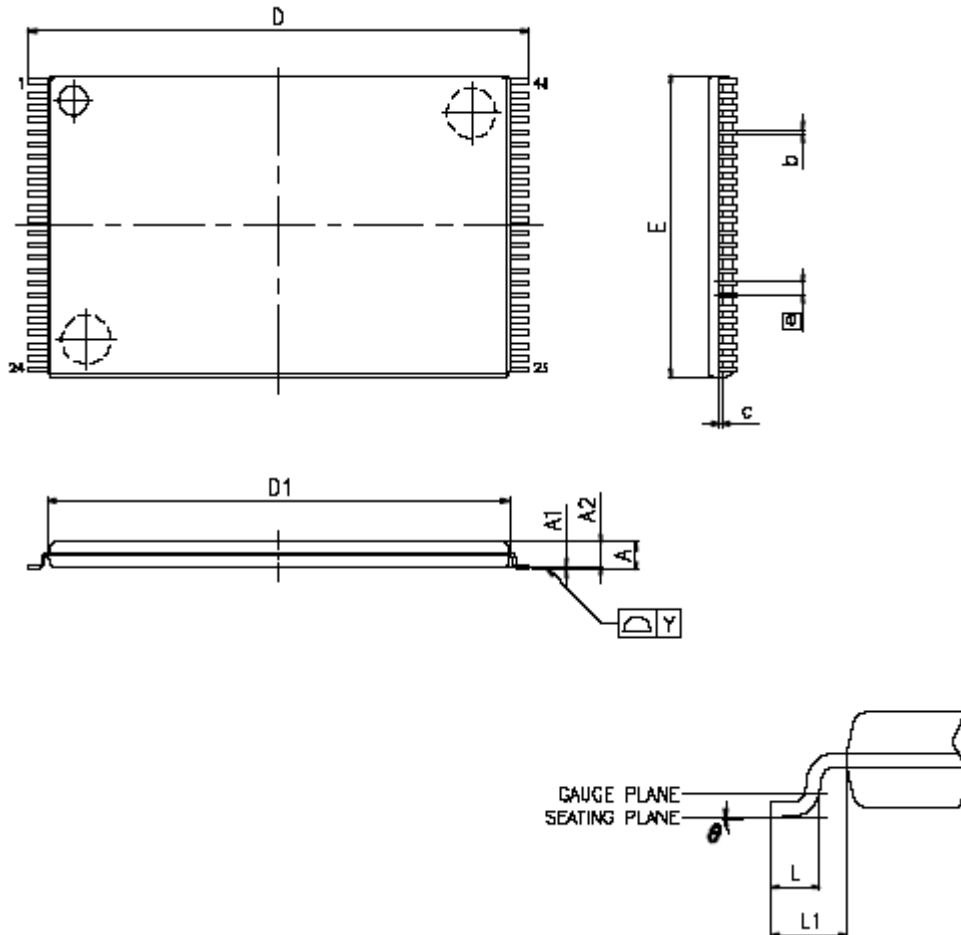
Low V_{CC} Data Retention Waveform (2) (CE2 controlled)

Low V_{CC} Data Retention Waveform (3) (LB#, UB# controlled)

PACKAGE OUTLINE DIMENSION
48-pin 12mm x 20mm TSOP-I Package Outline Dimension

VARIATIONS (ALL DIMENSIONS SHOWN IN MM)

SYMBOLS	MIN.	NOM.	MAX
A	-	-	1.20
A1	0.05	-	0.15
A2	0.95	1.00	1.05
b	0.17	0.22	0.27
c	0.10	-	0.21
Δ D	19.80	20.00	20.20
Δ D1	18.30	18.40	18.50
Δ E	11.90	12.00	12.10
\square	0.50 BASIC		
L	0.50	0.60	0.70
Δ L1	-	0.80	-
Δ Y	-	-	0.10
Δ θ	θ	-	5°

NOTES:

1. JEDEC OUTLINE : MO-142 DD
2. PROFILE TOLERANCE ZONES FOR D1 AND E DO NOT INCLUDE MOLD PROTRUSION. ALLOWABLE MOLD PROTRUSION ON E IS 0.15mm PER SIDE AND ON D1 IS 0.25mm PER SIDE.
3. DIMENSION b DOES NOT INCLUDE DAMBAR PROTRUSION. ALLOWABLE DAMBAR PROTRUSION SHALL BE 0.08mm TOTAL IN EXCESS OF THE b DIMENSION AT MAXIMUM MATERIAL CONDITION. DAMBAR CANNOT BE LOCATED ON THE LOWER RADIUS OR THE FOOT.

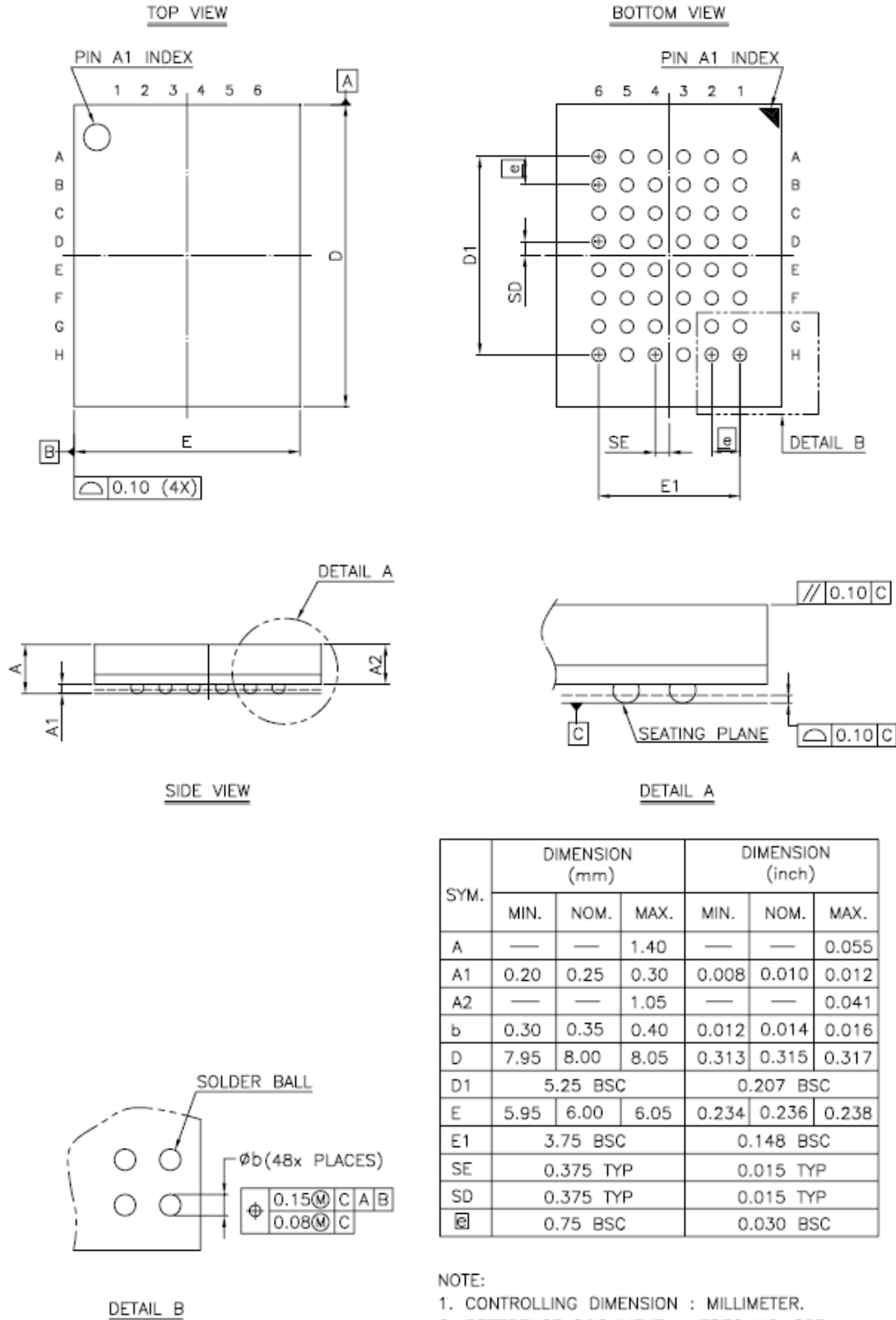
48-ball 6mm x 8mm TFBGA Package Outline Dimension

NOTE:

1. CONTROLLING DIMENSION : MILLIMETER.
2. REFERENCE DOCUMENT : JEDEC MO-207.



ORDERING INFORMATION

LY62L51316 U V - WW XX Y Z

Z : Packing Type

Blank : Tube or Tray
Tray : 48-pin 12 mm x 20 mm TSOP-I
48-ball 6 mm x 8 mm TFBGA
T : Tape Reel

Y : Temperature Range

Blank : (Commercial) 0°C ~ 70°C
I : (Industrial) -40°C ~ +85°C

XX : Power Type

LL : Ultra Low Power
SL : Special Ultra Low Power

WW : Access Time(Speed)

V : Lead Information

L : Green Package

U : Package Type

L : 48-pin 12 mm x 20 mm TSOP-I
G : 48-ball 6 mm x 8 mm TFBGA



Lyontek Inc.

LY62L51316

Rev. 1.6

512K X 16 BIT LOW POWER CMOS SRAM

THIS PAGE IS LEFT BLANK INTENTIONALLY.