



#### REVISION HISTORY

<u>Revision</u>	<u>Description</u>	<u>Issue Date</u>
Rev. 1.0	Initial Issue	Jul.25.2004
Rev. 1.1	Merge 2.7~3.6V and 4.5~5.5V to 2.7~5.5V	Jan.17.2005
Rev. 1.2	Revised <b>STSOP Package Outline Dimension</b>	Mar.26.2008
Rev. 1.3	Revised <b>FEATURES &amp; ORDERING INFORMATION</b> <b>Lead free and green package available</b> to <b>Green package available</b> Added packing type in <b>ORDERING INFORMATION</b> Revised $I_{SB1(MAX)}$ & $V_{DR(MIN)}$ Revised $V_{TERM}$ to $V_{T1}$ and $V_{T2}$ Revised Test Condition of $I_{SB1/IDR}$ Deleted $T_{SOLDER}$ in <b>ABSOLUTE MAXIMUM RATINGS</b>	Mar.30.2009
Rev. 1.4	Revised <b>PACKAGE OUTLINE DIMENSION</b> in page 10	May.7.2010

### FEATURES

- Fast access time : 35/55/70ns
- Low power consumption:  
 Operation current :  
     20/15/10mA (TYP.),  $V_{CC} = 3.0V$   
 Standby current :  
     1 $\mu A$  (TYP.),  $V_{CC} = 3.0V$
- Wide range power supply : 2.7 ~ 5.5V
- All inputs and outputs TTL compatible
- Fully static operation
- Tri-state output
- Data retention voltage : 1.5V (MIN.)
- **Green package available**
- Package : 28-pin 600 mil PDIP  
     28-pin 330 mil SOP  
     28-pin 8mm x 13.4mm STSOP

### GENERAL DESCRIPTION

The LY62W256 is a 262,144-bit low power CMOS static random access memory organized as 32,768 words by 8 bits. It is fabricated using very high performance, high reliability CMOS technology. Its standby current is stable within the range of operating temperature.

The LY62W256 is well designed for low power application, and particularly well suited for battery back-up nonvolatile memory application.

The LY62W256 operates with wide range power supply and all inputs and outputs are fully TTL compatible

### PRODUCT FAMILY

Product Family	Operating Temperature	Vcc Range	Speed
LY62W256	0 ~ 70°C	2.7 ~ 5.5V	35/55/70ns
LY62W256(E)	-20 ~ 80°C	2.7 ~ 5.5V	35/55/70ns
LY62W256(I)	-40 ~ 85°C	2.7 ~ 5.5V	35/55/70ns

### FUNCTIONAL BLOCK DIAGRAM

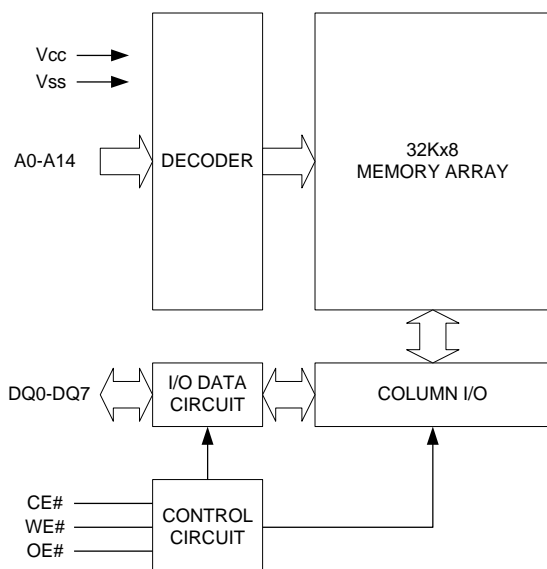

### PIN DESCRIPTION

SYMBOL	DESCRIPTION
A0 - A14	Address Inputs
DQ0 - DQ7	Data Inputs/Outputs
CE#	Chip Enable Input
WE#	Write Enable Input
OE#	Output Enable Input
Vcc	Power Supply
Vss	Ground

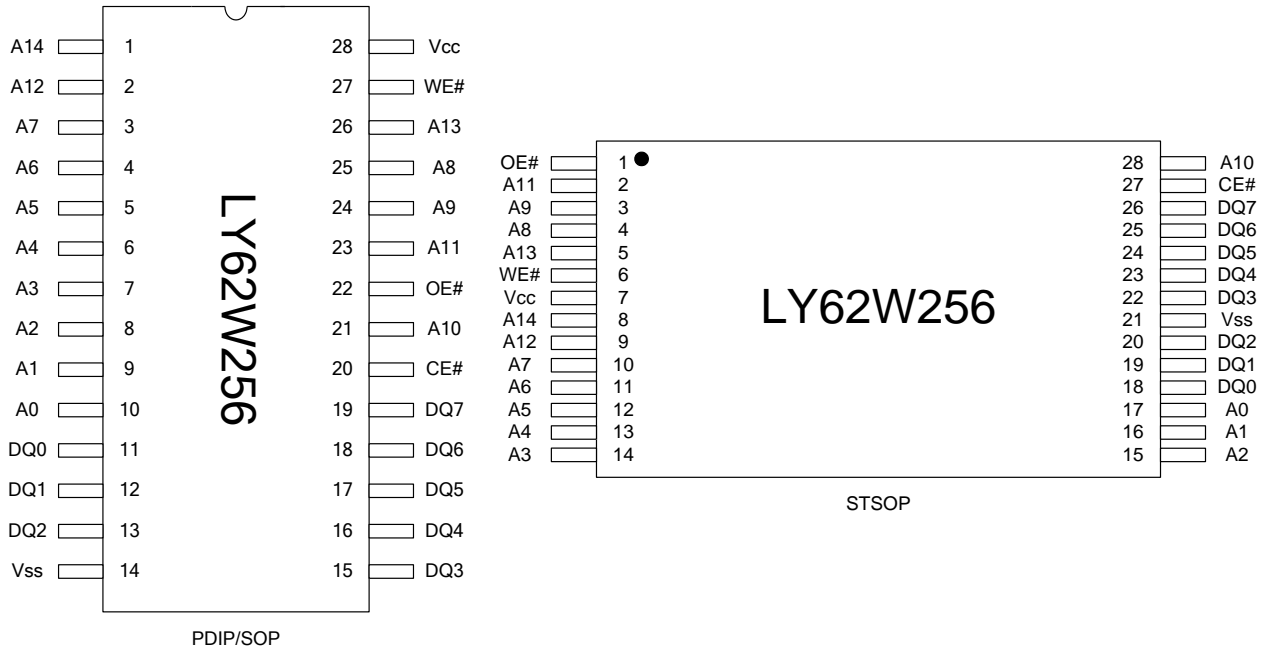
**PIN CONFIGURATION**

**ABSOLUTE MAXIMUM RATINGS\***

PARAMETER	SYMBOL	RATING	UNIT
Voltage on Vcc relative to Vss	$V_{T1}$	-0.5 to 6.5	V
Voltage on any other pin relative to Vss	$V_{T2}$	-0.5 to $V_{cc}+0.5$	V
Operating Temperature	$T_A$	0 to 70(C grade)	°C
		-20 to 80(E grade)	
		-40 to 85(I grade)	
Storage Temperature	$T_{STG}$	-65 to 150	°C
Power Dissipation	$P_D$	1	W
DC Output Current	$I_{OUT}$	50	mA

\*Stresses greater than those listed under "Absolute Maximum Ratings" may cause permanent damage to the device. This is a stress rating only and functional operation of the device or any other conditions above those indicated in the operational sections of this specification is not implied. Exposure to the absolute maximum rating conditions for extended period may affect device reliability.

**TRUTH TABLE**

MODE	CE#	OE#	WE#	I/O OPERATION	SUPPLY CURRENT
Standby	H	X	X	High-Z	$I_{SB}, I_{SB1}$
Output Disable	L	H	H	High-Z	$I_{CC}, I_{CC1}$
Read	L	L	H	DOUT	$I_{CC}, I_{CC1}$
Write	L	X	L	DIN	$I_{CC}, I_{CC1}$

Note: H =  $V_{IH}$ , L =  $V_{IL}$ , X = Don't care.

**DC ELECTRICAL CHARACTERISTICS**

PARAMETER	SYMBOL	TEST CONDITION	MIN.	TYP. <sup>5</sup>	MAX.	UNIT	
Supply Voltage	V <sub>CC</sub>		2.7	3.3	5.5	V	
Input High Voltage	V <sub>IH</sub> <sup>1</sup>		0.7*V <sub>CC</sub>	-	V <sub>CC</sub> +0.5	V	
Input Low Voltage	V <sub>IL</sub> <sup>2</sup>		- 0.5	-	0.6	V	
Input Leakage Current	I <sub>LI</sub>	V <sub>CC</sub> ≥ V <sub>IN</sub> ≥ V <sub>SS</sub>	- 1	-	1	μA	
Output Leakage Current	I <sub>LO</sub>	V <sub>CC</sub> ≥ V <sub>OUT</sub> ≥ V <sub>SS</sub> , Output Disabled	- 1	-	1	μA	
Output High Voltage	V <sub>OH</sub>	I <sub>OH</sub> = -1mA	2.4	3.0	-	V	
Output Low Voltage	V <sub>OL</sub>	I <sub>OL</sub> = 2mA	-	-	0.4	V	
Average Operating Power supply Current	I <sub>CC</sub>	Cycle time = Min. CE# = V <sub>IL</sub> , I <sub>I/O</sub> = 0mA Other pins at V <sub>IL</sub> or V <sub>IH</sub>	-35	-	20	50	mA
			-55	-	15	45	mA
			-70	-	10	40	mA
Average Operating Power supply Current	I <sub>CC1</sub>	Cycle time = 1μs CE# ≤ 0.2V and I <sub>I/O</sub> = 0mA other pins at 0.2V or V <sub>CC</sub> -0.2V	-	3	10	mA	
Standby Power Supply Current	I <sub>SB</sub>	CE# = V <sub>IH</sub> , others at V <sub>IL</sub> or V <sub>IH</sub>	-	1	3	mA	
	I <sub>SB1</sub>	CE# ≥ V <sub>CC</sub> - 0.2V Others at 0.2V or V <sub>CC</sub> - 0.2V	-	1	30 <sup>4</sup>	μA	

Notes:

- V<sub>IH</sub>(max) = V<sub>CC</sub> + 3.0V for pulse width less than 10ns.
- V<sub>IL</sub>(min) = V<sub>SS</sub> - 3.0V for pulse width less than 10ns.
- Over/Undershoot specifications are characterized, not 100% tested.
- 10μA for special request
- Typical values are included for reference only and are not guaranteed or tested.  
Typical values are measured at V<sub>CC</sub> = V<sub>CC</sub>(TYP.) and T<sub>A</sub> = 25°C

**CAPACITANCE (T<sub>A</sub> = 25°C, f = 1.0MHz)**

PARAMETER	SYMBOL	MIN.	MAX	UNIT
Input Capacitance	C <sub>IN</sub>	-	6	pF
Input/Output Capacitance	C <sub>I/O</sub>	-	8	pF

Note : These parameters are guaranteed by device characterization, but not production tested.

**AC TEST CONDITIONS**

Input Pulse Levels	0.2V to V <sub>CC</sub> - 0.2V
Input Rise and Fall Times	3ns
Input and Output Timing Reference Levels	1.5V
Output Load	C <sub>L</sub> = 50pF + 1TTL, I <sub>OH</sub> /I <sub>OL</sub> = -1mA/2mA



### AC ELECTRICAL CHARACTERISTICS

#### (1) READ CYCLE

PARAMETER	SYM.	LY62W256-35		LY62W256-55		LY62W256-70		UNIT
		MIN.	MAX.	MIN.	MAX.	MIN.	MAX.	
Read Cycle Time	t <sub>RC</sub>	35	-	55	-	70	-	ns
Address Access Time	t <sub>AA</sub>	-	35	-	55	-	70	ns
Chip Enable Access Time	t <sub>ACE</sub>	-	35	-	55	-	70	ns
Output Enable Access Time	t <sub>OE</sub>	-	25	-	30	-	35	ns
Chip Enable to Output in Low-Z	t <sub>CLZ</sub> *	10	-	10	-	10	-	ns
Output Enable to Output in Low-Z	t <sub>OLZ</sub> *	5	-	5	-	5	-	ns
Chip Disable to Output in High-Z	t <sub>CHZ</sub> *	-	15	-	20	-	25	ns
Output Disable to Output in High-Z	t <sub>OHZ</sub> *	-	15	-	20	-	25	ns
Output Hold from Address Change	t <sub>OH</sub>	10	-	10	-	10	-	ns

#### (2) WRITE CYCLE

PARAMETER	SYM.	LY62W256-35		LY62W256-55		LY62W256-70		UNIT
		MIN.	MAX.	MIN.	MAX.	MIN.	MAX.	
Write Cycle Time	t <sub>WC</sub>	35	-	55	-	70	-	ns
Address Valid to End of Write	t <sub>AW</sub>	30	-	50	-	60	-	ns
Chip Enable to End of Write	t <sub>CW</sub>	30	-	50	-	60	-	ns
Address Set-up Time	t <sub>AS</sub>	0	-	0	-	0	-	ns
Write Pulse Width	t <sub>WP</sub>	25	-	45	-	55	-	ns
Write Recovery Time	t <sub>WR</sub>	0	-	0	-	0	-	ns
Data to Write Time Overlap	t <sub>DW</sub>	20	-	25	-	30	-	ns
Data Hold from End of Write Time	t <sub>DH</sub>	0	-	0	-	0	-	ns
Output Active from End of Write	t <sub>OW</sub> *	5	-	5	-	5	-	ns
Write to Output in High-Z	t <sub>WHZ</sub> *	-	15	-	20	-	25	ns

\*These parameters are guaranteed by device characterization, but not production tested.

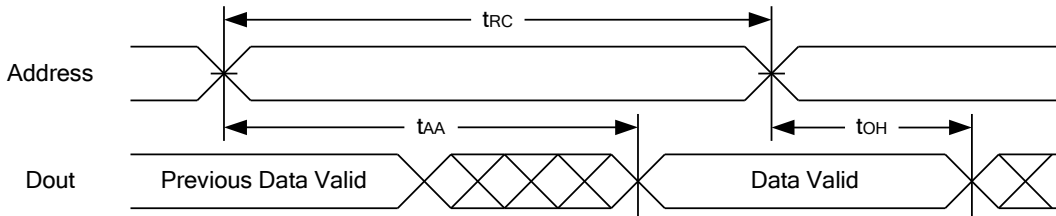
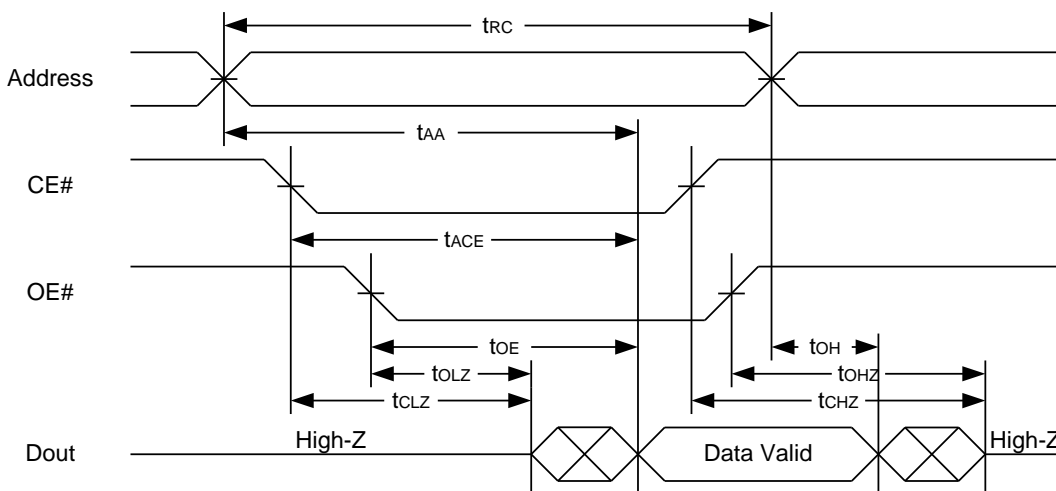
**TIMING WAVEFORMS**
**READ CYCLE 1 (Address Controlled) (1,2)**

**READ CYCLE 2 (CE# and OE# Controlled) (1,3,4,5)**

**Notes :**

1. WE# is high for read cycle.
2. Device is continuously selected OE# = low, CE# = low.
3. Address must be valid prior to or coincident with CE# = low; otherwise  $t_{AA}$  is the limiting parameter.
4.  $t_{CLZ}$ ,  $t_{OLZ}$ ,  $t_{CHZ}$  and  $t_{OZH}$  are specified with  $C_L = 5pF$ . Transition is measured  $\pm 500mV$  from steady state.
5. At any given temperature and voltage condition,  $t_{CHZ}$  is less than  $t_{CLZ}$ ,  $t_{OZH}$  is less than  $t_{OLZ}$ .



**DATA RETENTION CHARACTERISTICS**

PARAMETER	SYMBOL	TEST CONDITION	MIN.	TYP.	MAX.	UNIT
V <sub>CC</sub> for Data Retention	V <sub>DR</sub>	CE# ≥ V <sub>CC</sub> - 0.2V	1.5	-	5.5	V
Data Retention Current	I <sub>DR</sub>	V <sub>CC</sub> = 1.5V CE# ≥ V <sub>CC</sub> - 0.2V Others at 0.2V or V <sub>CC</sub> -0.2V	-	0.5	20	μA
Chip Disable to Data Retention Time	t <sub>CDR</sub>	See Data Retention Waveforms (below)	0	-	-	ns
Recovery Time	t <sub>R</sub>		t <sub>RC</sub> *	-	-	ns

 t<sub>RC</sub>\* = Read Cycle Time

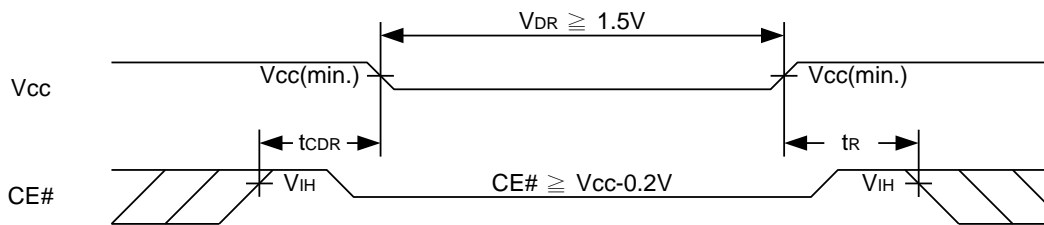
**DATA RETENTION WAVEFORM**

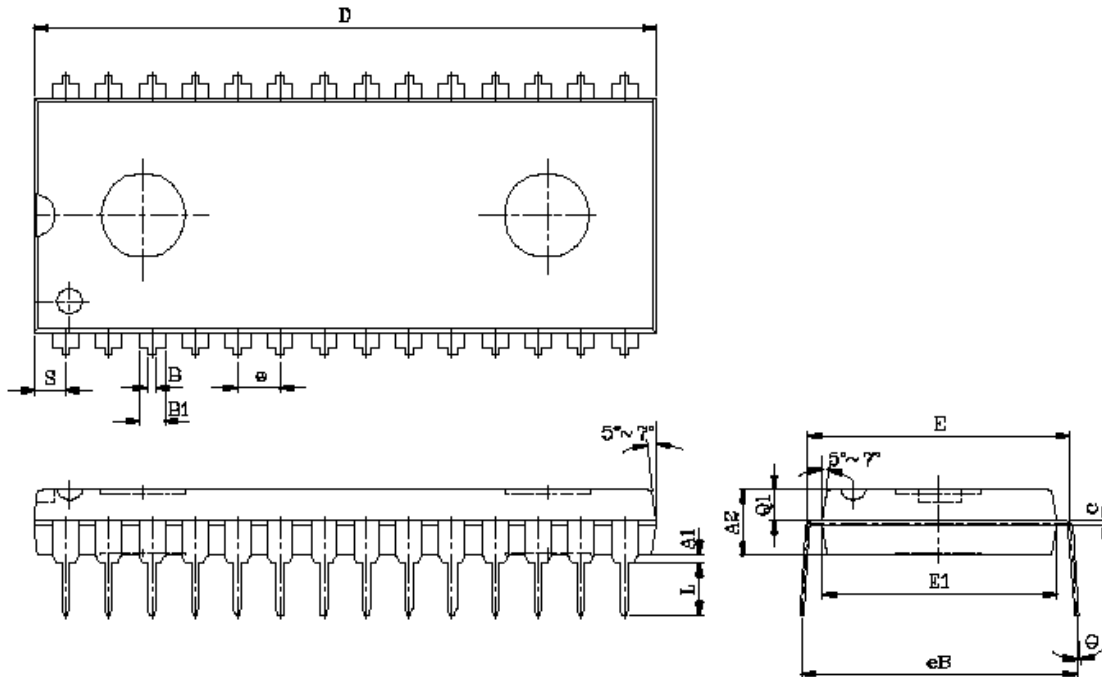
**PACKAGE OUTLINE DIMENSION**
**28 pin 600 mil PDIP Package Outline Dimension**

SYM.	UNIT	INCH.(BASE)	MM(REF)
A1		0.010 (MIN)	0.254 (MIN)
A2		0.150±0.005	3.810±0.127
B		0.020 (MAX)	0.508(MAX)
B1		0.055 (MAX)	1.397(MAX)
c		0.012 (MAX)	0.304 (MAX)
D		1.430 (MAX)	36.322 (MAX)
E		0.6 (TYP)	15.24 (TYP)
E1		0.52 (MAX)	13.208 (MAX)
e		0.100 (TYP)	2.540(TYP)
eB		0.625 (MAX)	15.87 (MAX)
L		0.180(MAX)	4.572(MAX)
S		0.06 (MAX)	1.524 (MAX)
Q1		0.08(MAX)	2.032(MAX)
Θ		15°(MAX)	15°(MAX)

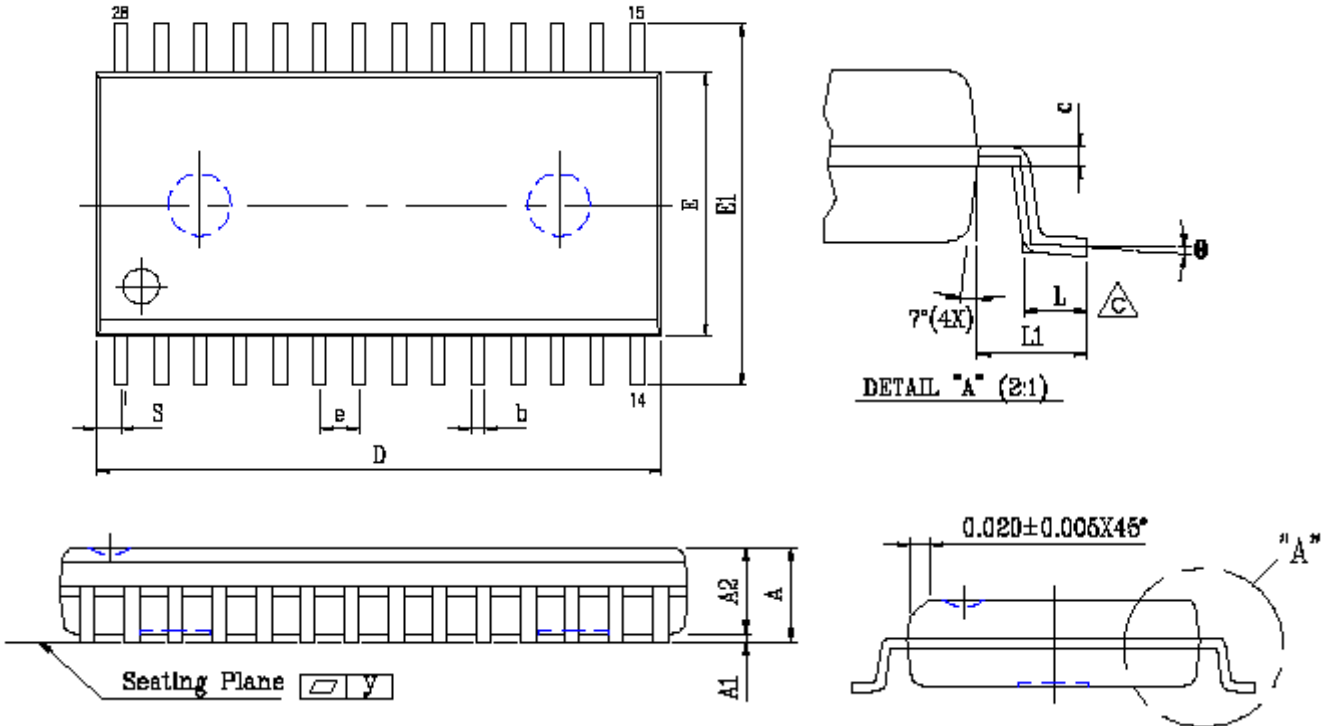
**28 pin 330 mil SOP Package Outline Dimension**

SYM.	UNIT	INCH(BASE)	MM(REF)
A		0.120 (MAX)	3.048 (MAX)
A1		0.002(MIN)	0.05(MIN)
A2		0.098±0.005	2.489±0.127
b		0.016 (TYP)	0.406(TYP)
c		0.010 (TYP)	0.254(TYP)
D		0.728 (MAX)	18.491 (MAX)
E		0.340 (MAX)	8.636 (MAX)
E1		0.465±0.012	11.811±0.305
e		0.050 (TYP)	1.270(TYP)
L		0.05 (MAX)	1.270 (MAX)
L1		0.067±0.008	1.702 ±0.203
S		0.047 (MAX)	1.194 (MAX)
y		0.003(MAX)	0.076(MAX)
θ		0°~10°	0°~10°

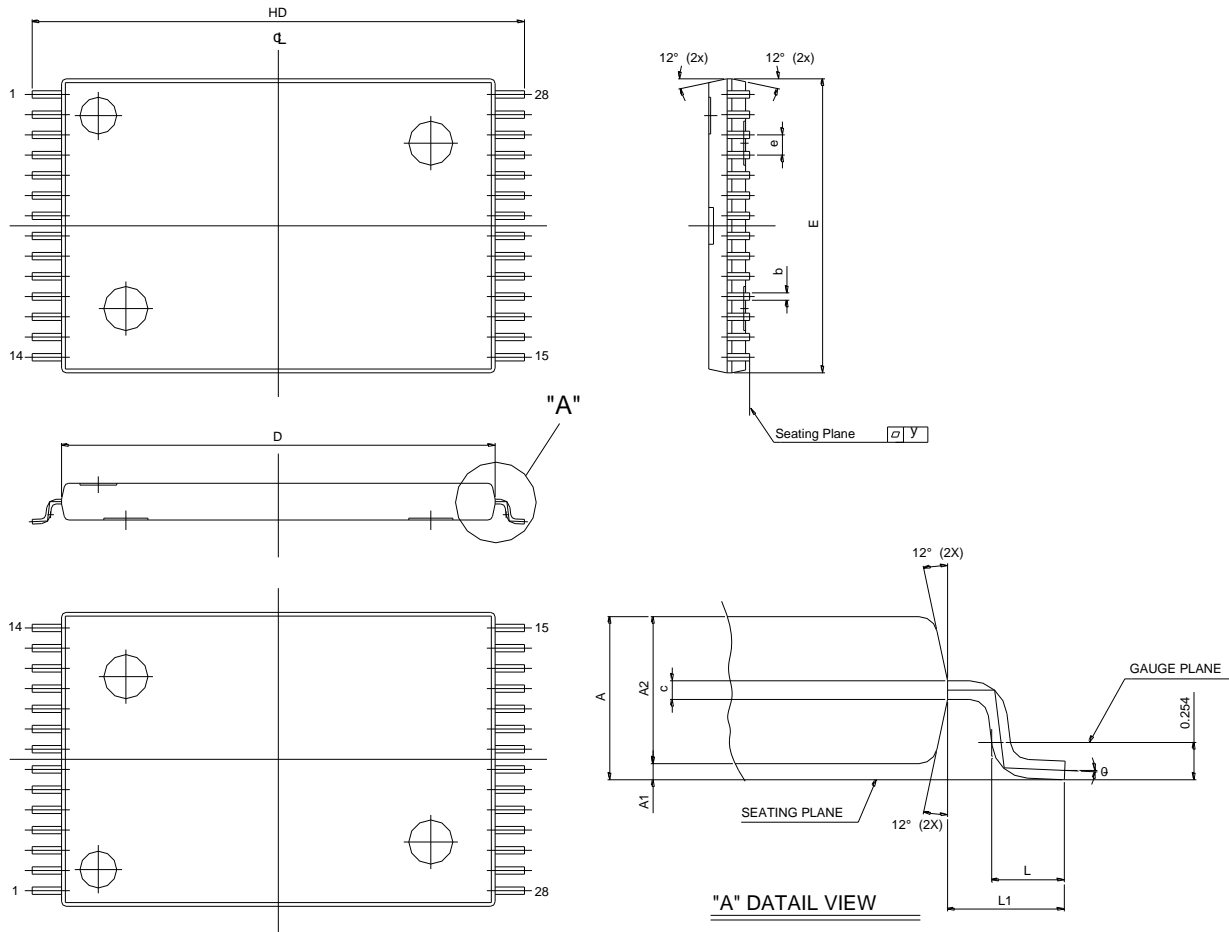
**28 pin 8x13.4mm STSOP Package Outline Dimension**

SYMBOLS	DIMENSIONS IN MILLIMETERS			DIMENSIONS IN INCHES		
	MIN	NOM	MAX	MIN	NOM	MAX
A	1.00	1.10	1.20	0.040	0.043	0.047
A1	0.05	-	0.15	0.002	-	0.006
A2	0.91	1.00	1.05	0.036	0.039	0.041
b	0.17	0.22	0.27	0.007	0.009	0.011
c	0.07	0.15	0.23	0.003	0.006	0.009
HD	13.20	13.40	13.60	0.520	0.528	0.535
D	11.60	11.80	12.00	0.457	0.465	0.472
E	7.80	8.00	8.20	0.307	0.315	0.323
e	-	0.55	-	-	0.0216	-
L	0.30	0.50	0.70	0.012	0.020	0.028
L1	0.675	-	-	0.027	-	-
Y	0.00	-	0.076	0.000	-	0.003
Θ	0°	3°	5°	0°	3°	5°



#### ORDERING INFORMATION

LY62W256 U V - WW XX Y Z

**Z** : Packing Type  
Blank : Tube or Tray  
T : Tape Reel

**Y** : Temperature Range  
Blank : (Commercial) 0°C ~ 70°C  
E : (Extended) -20°C ~ +80°C  
I : (Industrial) -40°C ~ +85°C

**XX** : Power Type  
LL : Ultra Low Power

**WW** : Access Time(Speed)

**V** : Lead Information  
L : Green Package

**U** : Package Type  
P : 28-pin 600 mil P-DIP  
S : 28-pin 330 mil SOP  
R : 28-pin 8 mm x 13.4 mm STSOP

THIS PAGE IS LEFT BLANK INTENTIONALLY.