



REVISION HISTORY

<u>Revision</u>	<u>Description</u>	<u>Issue Date</u>
Rev. 1.0	Initial Issue	Dec.1.2006
Rev. 1.1	Revised V_{IH} to TTL compatible	Jan.9.2008
Rev. 1.2	Revised V_{IH} to $0.7 \cdot V_{CC}$	May.6.2008
Rev. 1.3	Revised V_{DR}	Mar.3.2009
Rev. 1.4	Revised V_{TERM} to V_{T1} and V_{T2} Revised Test Condition of I_{SB1}/I_{DR} Revised FEATURES & ORDERING INFORMATION <u>Lead free and green package available to Green package available</u> Added packing type in ORDERING INFORMATION Deleted T_{SOLDER} in ABSOLUTE MAXIMUM RATINGS Adding PKG type : 32 TSOP-II	Aug.5.2009
Rev. 1.5	Revised PACKAGE OUTLINE DIMENSION in page 9/10/11	May.7.2010
Rev. 1.6	Revised typo in PIN CONFIGURATION	Jul.21.2010
Rev. 1.7	Revised ORDERING INFORMATION in page 12 Revised PACKAGE OUTLINE DIMENSION in page 8/12	Aug.25.2010
Rev. 1.8	Revised typo in REVISION HISTORY ORDERING INFORMATION in page 12 to 13	Oct.29.2010
Rev. 1.9	Added SL Grade Deleted E Grade Revised I_{SB1}/I_{DR}	Aug.9.2011
Rev. 1.10	Added PKG type : 32 P-DIP	Nov.24.2011

FEATURES

- Fast access time : 55/70ns
- Low power consumption:
 Operating current : 30/20mA (TYP.)
 Standby current : 2 μ A (TYP.) LL-version
 1 μ A (TYP.) SL-version
- Single 2.7V ~ 5.5V power supply
- All outputs TTL compatible
- Fully static operation
- Tri-state output
- Data retention voltage : 1.5V (MIN.)
- **Green package available**
- Package : 32-pin 450 mil SOP
 32-pin 8mm x 20mm TSOP-I
 32-pin 8mm x 13.4mm STSOP
 36-ball 6mm x 8mm TFBGA
 32-pin 400 mil TSOP-II
 32-pin 600 mil P-DIP

GENERAL DESCRIPTION

The LY62W5128 is a 4,194,304-bit low power CMOS static random access memory organized as 524,288 words by 8 bits. It is fabricated using very high performance, high reliability CMOS technology. Its standby current is stable within the range of operating temperature.

The LY62W5128 is well designed for very low power system applications, and particularly well suited for battery back-up nonvolatile memory application.

The LY62W5128 operates from a single power supply of 2.7V ~ 5.5V and all inputs and outputs are fully TTL compatible

PRODUCT FAMILY

Product Family	Operating Temperature	Vcc Range	Speed	Power Dissipation	
				Standby(I _{SB1} TYP.)	Operating(I _{CC} ,TYP.)
LY62W5128	0 ~ 70°C	2.7 ~ 5.5V	55/70ns	2 μ A(LL)/1 μ A(SL)	30/20mA
LY62W5128(I)	-40 ~ 85°C	2.7 ~ 5.5V	55/70ns	2 μ A(LL)/1 μ A(SL)	30/20mA

FUNCTIONAL BLOCK DIAGRAM

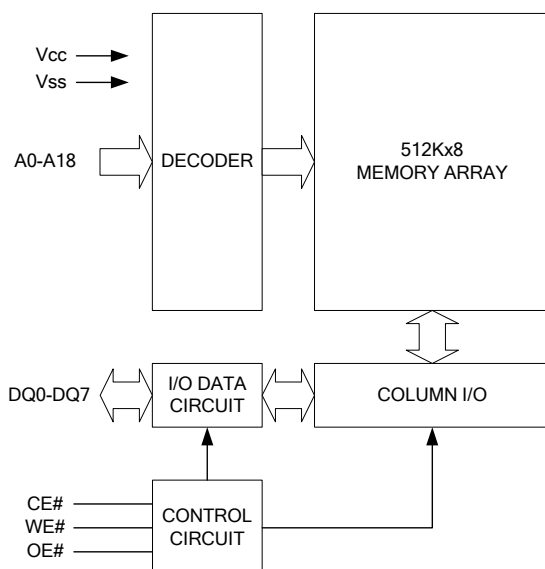

PIN DESCRIPTION

SYMBOL	DESCRIPTION
A0 - A18	Address Inputs
DQ0 - DQ7	Data Inputs/Outputs
CE#	Chip Enable Inputs
WE#	Write Enable Input
OE#	Output Enable Input
Vcc	Power Supply
Vss	Ground
NC	No Connection



PIN CONFIGURATION

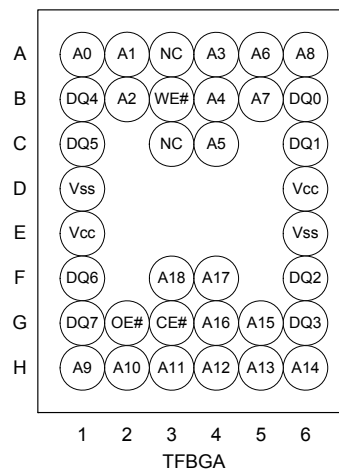
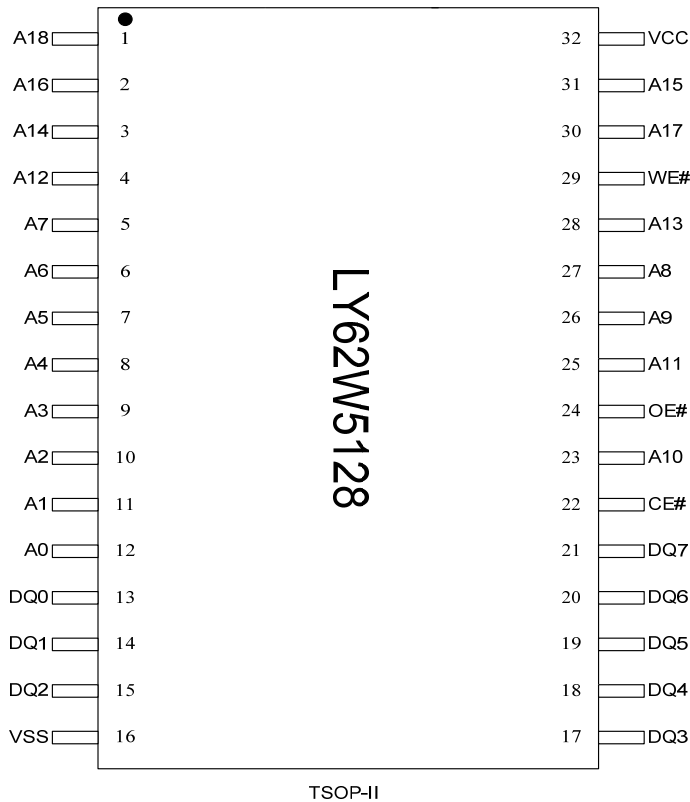
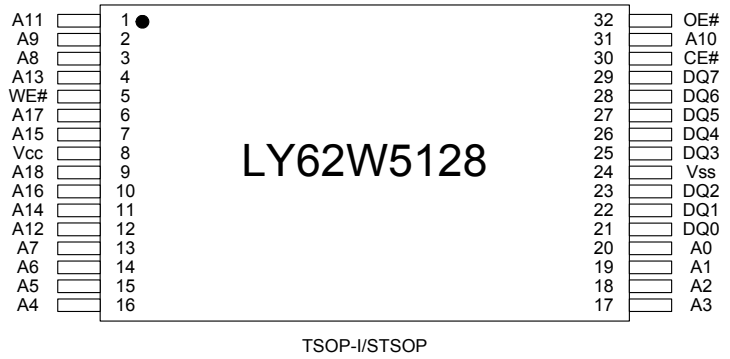
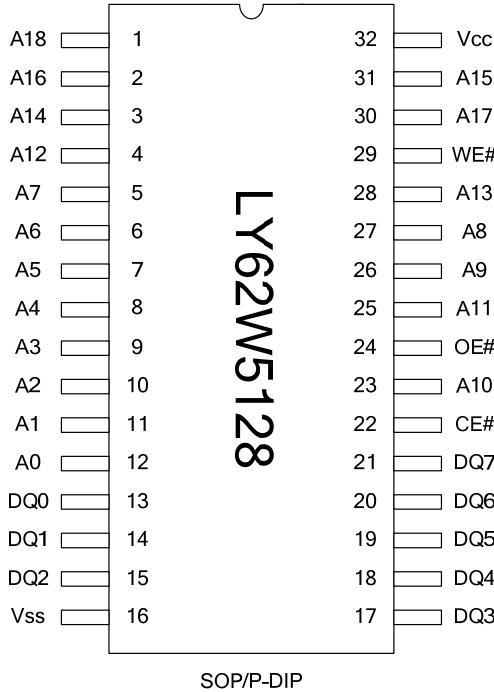

ABSOLUTE MAXIMUM RATINGS*

PARAMETER	SYMBOL	RATING	UNIT
Voltage on V _{CC} relative to V _{SS}	V _{T1}	-0.5 to 6.5	V
Voltage on any other pin relative to V _{SS}	V _{T2}	-0.5 to V _{CC} +0.5	V
Operating Temperature	T _A	0 to 70(C grade)	°C
		-40 to 85(I grade)	
Storage Temperature	T _{STG}	-65 to 150	°C
Power Dissipation	P _D	1	W
DC Output Current	I _{OUT}	50	mA

*Stresses greater than those listed under "Absolute Maximum Ratings" may cause permanent damage to the device. This is a stress rating only and functional operation of the device or any other conditions above those indicated in the operational sections of this specification is not implied. Exposure to the absolute maximum rating conditions for extended period may affect device reliability.

TRUTH TABLE

MODE	CE#	OE#	WE#	I/O OPERATION	SUPPLY CURRENT
Standby	H	X	X	High-Z	I _{SB1}
Output Disable	L	H	H	High-Z	I _{CC} , I _{CC1}
Read	L	L	H	D _{OUT}	I _{CC} , I _{CC1}
Write	L	X	L	D _{IN}	I _{CC} , I _{CC1}

Note: H = V_{IH}, L = V_{IL}, X = Don't care.

DC ELECTRICAL CHARACTERISTICS

PARAMETER	SYMBOL	TEST CONDITION	MIN.	TYP. ⁴	MAX.	UNIT	
Supply Voltage	V _{CC}		2.7	3.0	5.5	V	
Input High Voltage	V _{IH} ¹		0.7*V _{CC}	-	V _{CC} +0.3	V	
Input Low Voltage	V _{IL} ²		-0.2	-	0.6	V	
Input Leakage Current	I _{LI}	V _{CC} ≥ V _{IN} ≥ V _{SS}	-1	-	1	μA	
Output Leakage Current	I _{LO}	V _{CC} ≥ V _{OUT} ≥ V _{SS} , Output Disabled	-1	-	1	μA	
Output High Voltage	V _{OH}	I _{OH} = -1mA	2.4	2.7	-	V	
Output Low Voltage	V _{OL}	I _{OL} = 2mA	-	-	0.4	V	
Average Operating Power supply Current	I _{CC}	Cycle time = Min. CE# = V _{IL} and CE2 = V _{IH} , I _{I/O} = 0mA Other pins at V _{IL} or V _{IH}	-55	30	60	mA	
			-70	20	50	mA	
	I _{CC1}	Cycle time = 1μs CE# ≤ 0.2V and CE2 ≥ V _{CC} -0.2V,, I _{I/O} = 0mA Other pins at 0.2V or V _{CC} -0.2V	-	4	10	mA	
Standby Power Supply Current	I _{SB1}	CE# ≥ V _{CC} -0.2V or CE2 ≤ 0.2V Others at 0.2V or V _{CC} - 0.2V	LL/LLI	2	50	μA	
			SL ⁵	25°C	1	10	μA
			SLI ⁵	40°C	1	10	μA
			SL/SLI	1	25	μA	

Notes:

1. $V_{IH(max)} = V_{CC} + 3.0V$ for pulse width less than 10ns.
2. $V_{IL(min)} = V_{SS} - 3.0V$ for pulse width less than 10ns.
3. Over/Undershoot specifications are characterized, not 100% tested.
4. Typical values are included for reference only and are not guaranteed or tested.
Typical values are measured at $V_{CC} = V_{CC(TYP.)}$ and $T_A = 25^\circ C$
5. This parameter is measured at $V_{CC} = 3.0V$

CAPACITANCE ($T_A = 25^\circ C, f = 1.0MHz$)

PARAMETER	SYMBOL	MIN.	MAX	UNIT
Input Capacitance	C_{IN}	-	6	pF
Input/Output Capacitance	$C_{I/O}$	-	8	pF

Note : These parameters are guaranteed by device characterization, but not production tested.

AC TEST CONDITIONS

Input Pulse Levels	0.2V to $V_{CC} - 0.2V$
Input Rise and Fall Times	3ns
Input and Output Timing Reference Levels	1.5V
Output Load	$C_L = 30pF + 1TTL, I_{OH}/I_{OL} = -2mA/4mA$

AC ELECTRICAL CHARACTERISTICS
(1) READ CYCLE

PARAMETER	SYM.	LY62W5128-55		LY62W5128-70		UNIT
		MIN.	MAX.	MIN.	MAX.	
Read Cycle Time	t_{RC}	55	-	70	-	ns
Address Access Time	t_{AA}	-	55	-	70	ns
Chip Enable Access Time	t_{ACE}	-	55	-	70	ns
Output Enable Access Time	t_{OE}	-	30	-	35	ns
Chip Enable to Output in Low-Z	t_{CLZ}^*	10	-	10	-	ns
Output Enable to Output in Low-Z	t_{OLZ}^*	5	-	5	-	ns
Chip Disable to Output in High-Z	t_{CHZ}^*	-	20	-	25	ns
Output Disable to Output in High-Z	t_{OHZ}^*	-	20	-	25	ns
Output Hold from Address Change	t_{OH}	10	-	10	-	ns

(2) WRITE CYCLE

PARAMETER	SYM.	LY62W5128-55		LY62W5128-70		UNIT
		MIN.	MAX.	MIN.	MAX.	
Write Cycle Time	t_{WC}	55	-	70	-	ns
Address Valid to End of Write	t_{AW}	50	-	60	-	ns
Chip Enable to End of Write	t_{CW}	50	-	60	-	ns
Address Set-up Time	t_{AS}	0	-	0	-	ns
Write Pulse Width	t_{WP}	45	-	55	-	ns
Write Recovery Time	t_{WR}	0	-	0	-	ns
Data to Write Time Overlap	t_{DW}	25	-	30	-	ns
Data Hold from End of Write Time	t_{DH}	0	-	0	-	ns
Output Active from End of Write	t_{OW}^*	5	-	5	-	ns
Write to Output in High-Z	t_{WHZ}^*	-	20	-	25	ns

*These parameters are guaranteed by device characterization, but not production tested.



TIMING WAVEFORMS

READ CYCLE 1 (Address Controlled) (1,2)

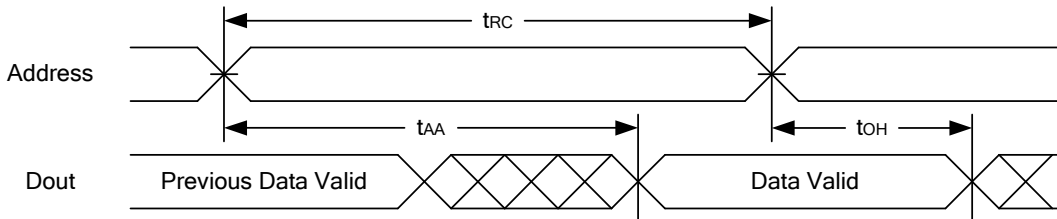

READ CYCLE 2 (CE# and OE# Controlled) (1,3,4,5)

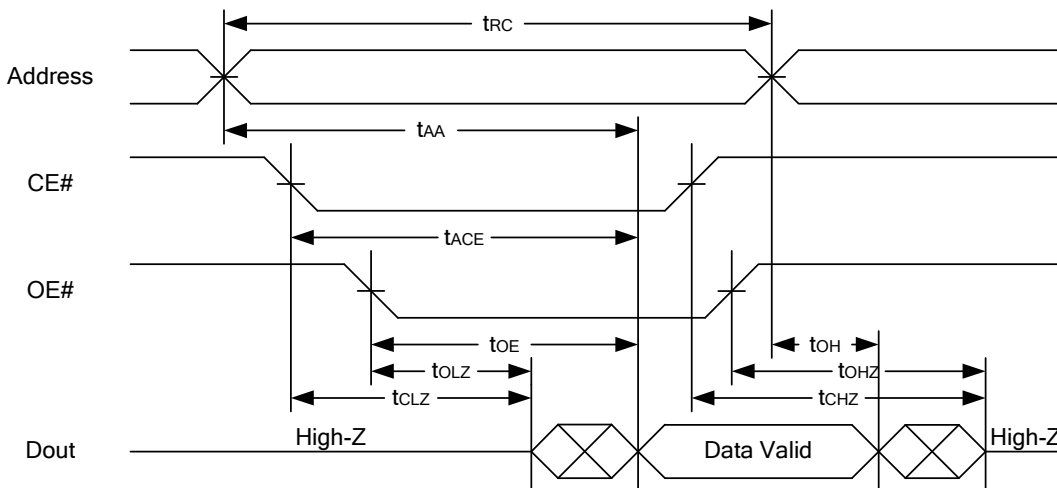

Notes :

1. WE# is high for read cycle.
2. Device is continuously selected OE# = low, CE# = low.
3. Address must be valid prior to or coincident with CE# = low; otherwise tAA is the limiting parameter.
4. tCLZ, tOLZ, tCHZ and tOHZ are specified with CL = 5pF. Transition is measured ±500mV from steady state.
5. At any given temperature and voltage condition, tCHZ is less than tCLZ, tOHZ is less than tOLZ.



WRITE CYCLE 1 (WE# Controlled) (1,2,3,5,6)

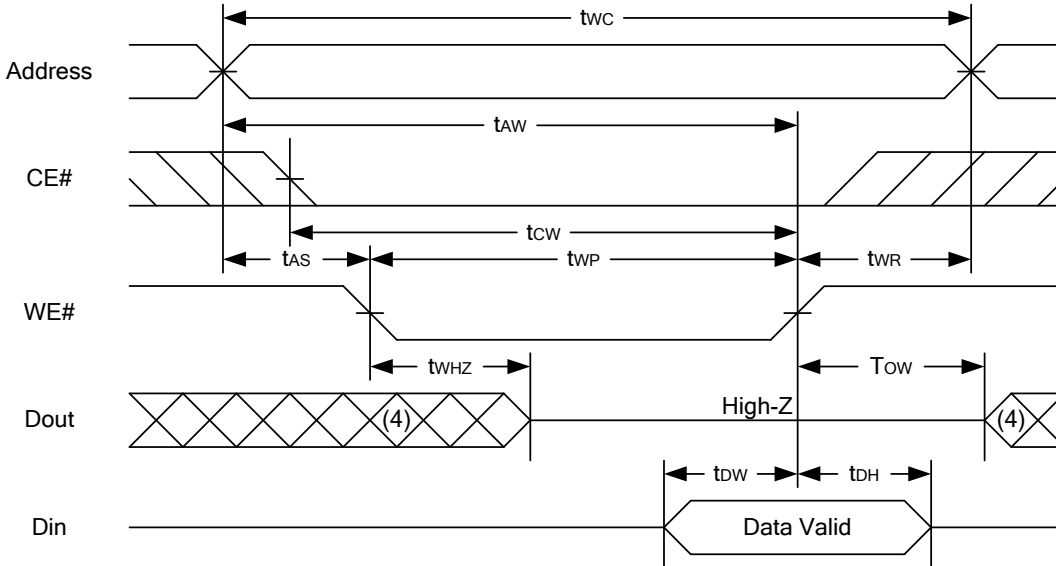

WRITE CYCLE 2 (CE# Controlled) (1,2,5,6)

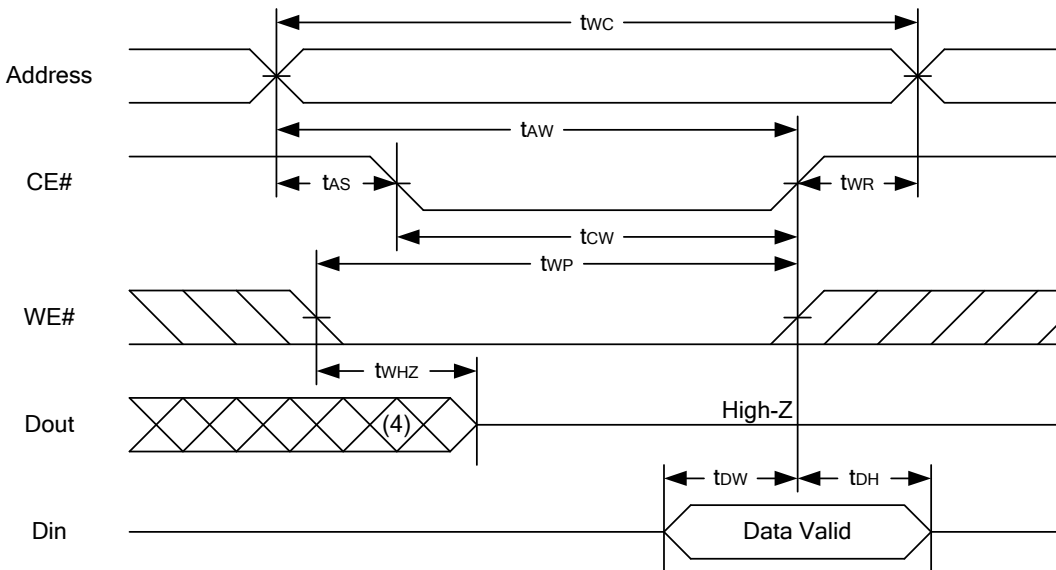

Notes :

1. WE#, CE# must be high during all address transitions.
2. A write occurs during the overlap of a low CE#, low WE#.
3. During a WE# controlled write cycle with OE# low, tWP must be greater than tWHZ + tDW to allow the drivers to turn off and data to be placed on the bus.
4. During this period, I/O pins are in the output state, and input signals must not be applied.
5. If the CE# low transition occurs simultaneously with or after WE# low transition, the outputs remain in a high impedance state.
6. tOW and tWHZ are specified with CL = 5pF. Transition is measured ±500mV from steady state.

DATA RETENTION CHARACTERISTICS

PARAMETER	SYMBOL	TEST CONDITION	MIN.	TYP.	MAX.	UNIT	
V _{CC} for Data Retention	V _{DR}	CE# ≥ V _{CC} - 0.2V or CE2 ≤ 0.2V	1.5	-	5.5	V	
Data Retention Current	I _{DR}	V _{CC} = 1.5V CE# ≥ V _{CC} - 0.2V or CE2 ≤ 0.2V Other pins at 0.2V or V _{CC} -0.2V	LL/LLI	-	1.0	30	μA
			SL 25°C	-	0.5	8	μA
			SLI 40°C	-	0.5	8	μA
			SL/SLI	-	0.5	23	μA
Chip Disable to Data Retention Time	t _{CDR}	See Data Retention Waveforms (below)	0	-	-	ns	
Recovery Time	t _R		t _{RC*}	-	-	ns	

 t_{RC*} = Read Cycle Time

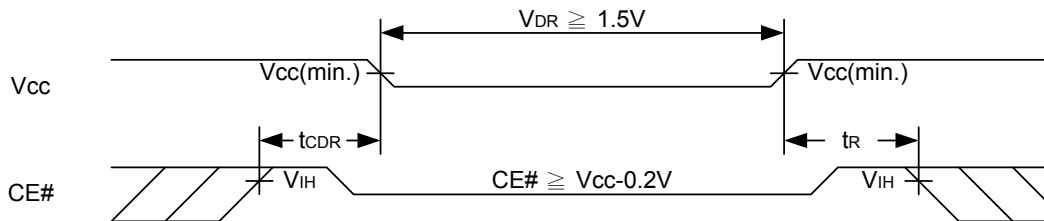
DATA RETENTION WAVEFORM



PACKAGE OUTLINE DIMENSION

32 pin 450 mil SOP Package Outline Dimension

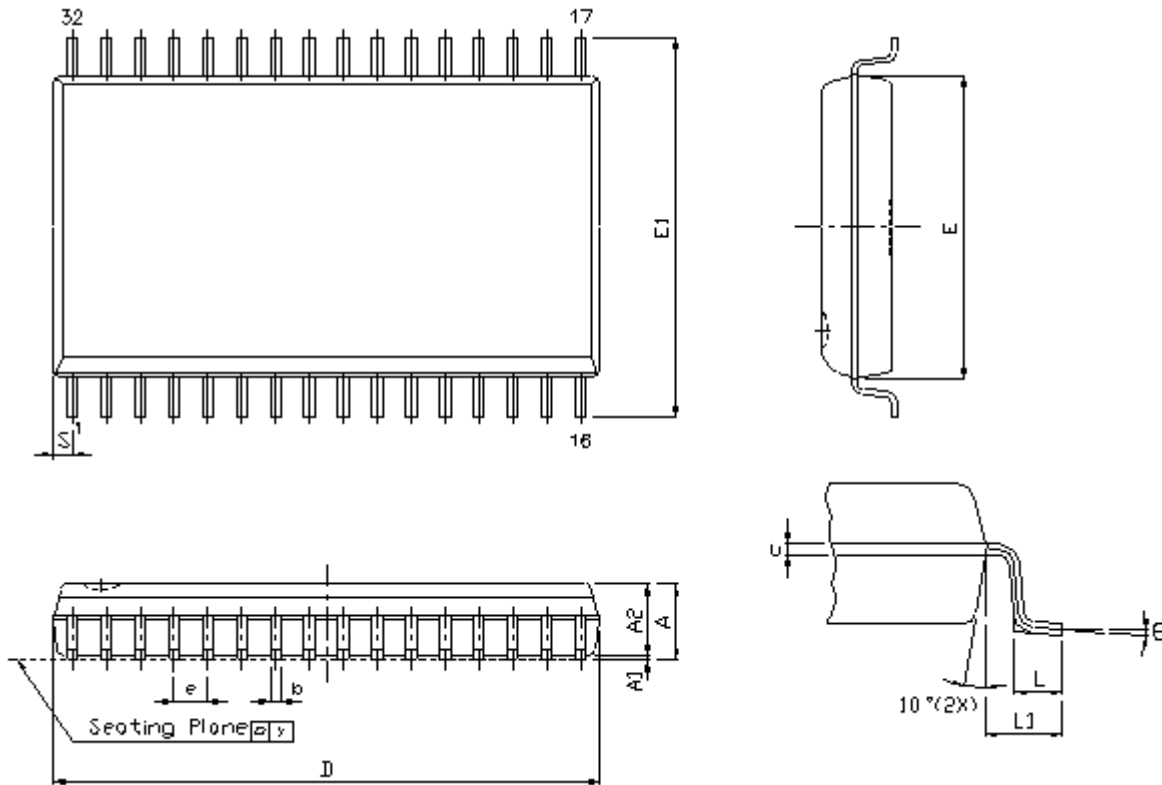

SYM.	UNIT	INCH.(BASE)	MM(REF)
A		0.120(MAX)	3.048(MAX)
A1		0.004(MIN)	0.102(MIN)
A2		0.116(MAX)	2.946(MAX)
b		0.016(TYP)	0.406(TYP)
c		0.008(TYP)	0.203(TYP)
D		0.817(MAX)	20.75(MAX)
E		0.445±0.006	11.303±0.152
E1		0.555±0.025	14.097±0.635
e		0.050(TYP)	1.270(TYP)
L		0.033±0.017	0.838±0.432
L1		0.055±0.008	1.397±0.203
S		0.026(MAX)	0.660(MAX)
y		0.004(MAX)	0.101(MAX)
Θ		0° -10°	0° -10°

32 pin 8mm x 20mm TSOP-I Package Outline Dimension

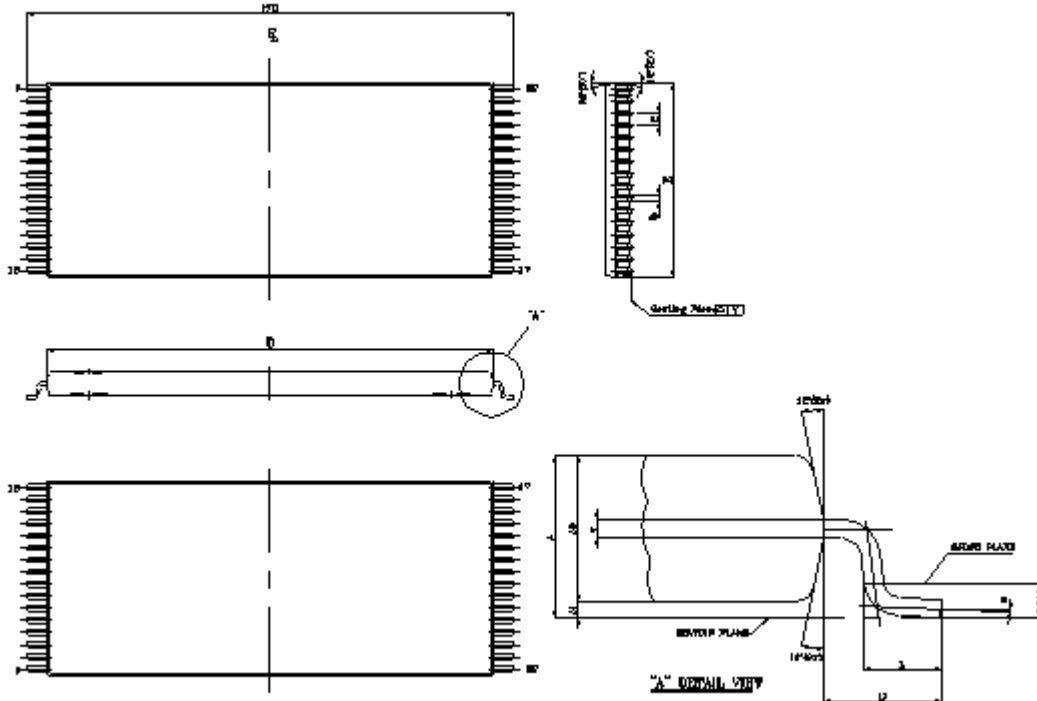

SYM.	UNIT	INCH(BASE)	MM(REF)
A		0.047 (MAX)	1.20 (MAX)
A1		0.004 ±0.002	0.10 ±0.05
A2		0.039 ±0.002	1.00 ±0.05
b		0.009 ±0.002	0.22 ±0.05
c		0.006 ±0.002	0.155 ±0.055
D		0.724 ±0.008	18.40 ±0.20
E		0.315 ±0.008	8.00 ±0.20
e		0.020 (TYP)	0.50 (TYP)
HD		0.787 ±0.008	20.00 ±0.20
L		0.024 ±0.004	0.60 ±0.10
L1		0.0315 ±0.004	0.08 ±0.10
y		0.003 (MAX)	0.08 (MAX)
Θ		0°~5°	0°~5°

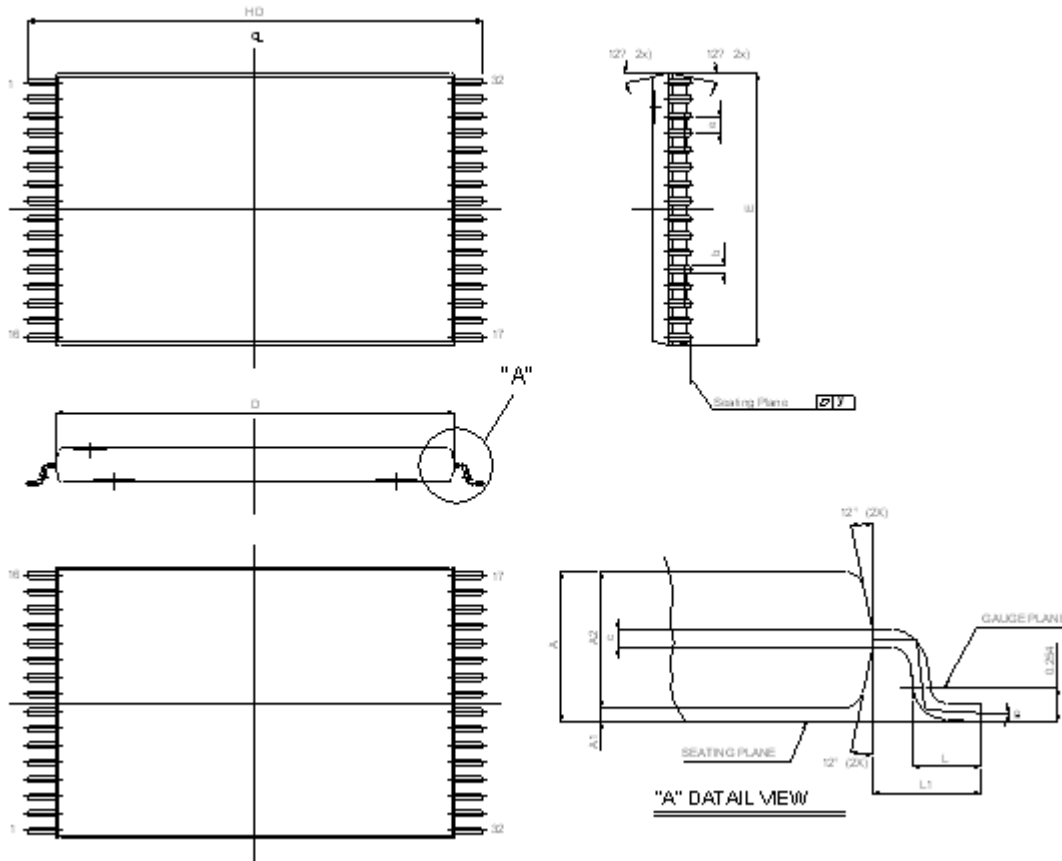
32 pin 8mm x 13.4mm STSOP Package Outline Dimension

SYM.	UNIT	INCH(BASE)	MM(REF)
A		0.049 (MAX)	1.25 (MAX)
A1		0.004 ±0.002	0.10 ±0.05
A2		0.039 ±0.002	1.00 ±0.05
b		0.009 ±0.002	0.22 ±0.05
c		0.006 ±0.002	0.155 ±0.055
D		0.465 ±0.008	11.80 ±0.20
E		0.315 ±0.008	8.00 ±0.20
e		0.020 (TYP)	0.50 (TYP)
HD		0.528±0.008	13.40 ±0.20.
L		0.02 ±0.008	0.50 ±0.20
L1		0.031 ±0.005	0.8 ±0.125
y		0.003 (MAX)	0.076 (MAX)
Θ		0°~5°	0°~5°



36 ball 6mm x 8mm TFBGA Package Outline Dimension

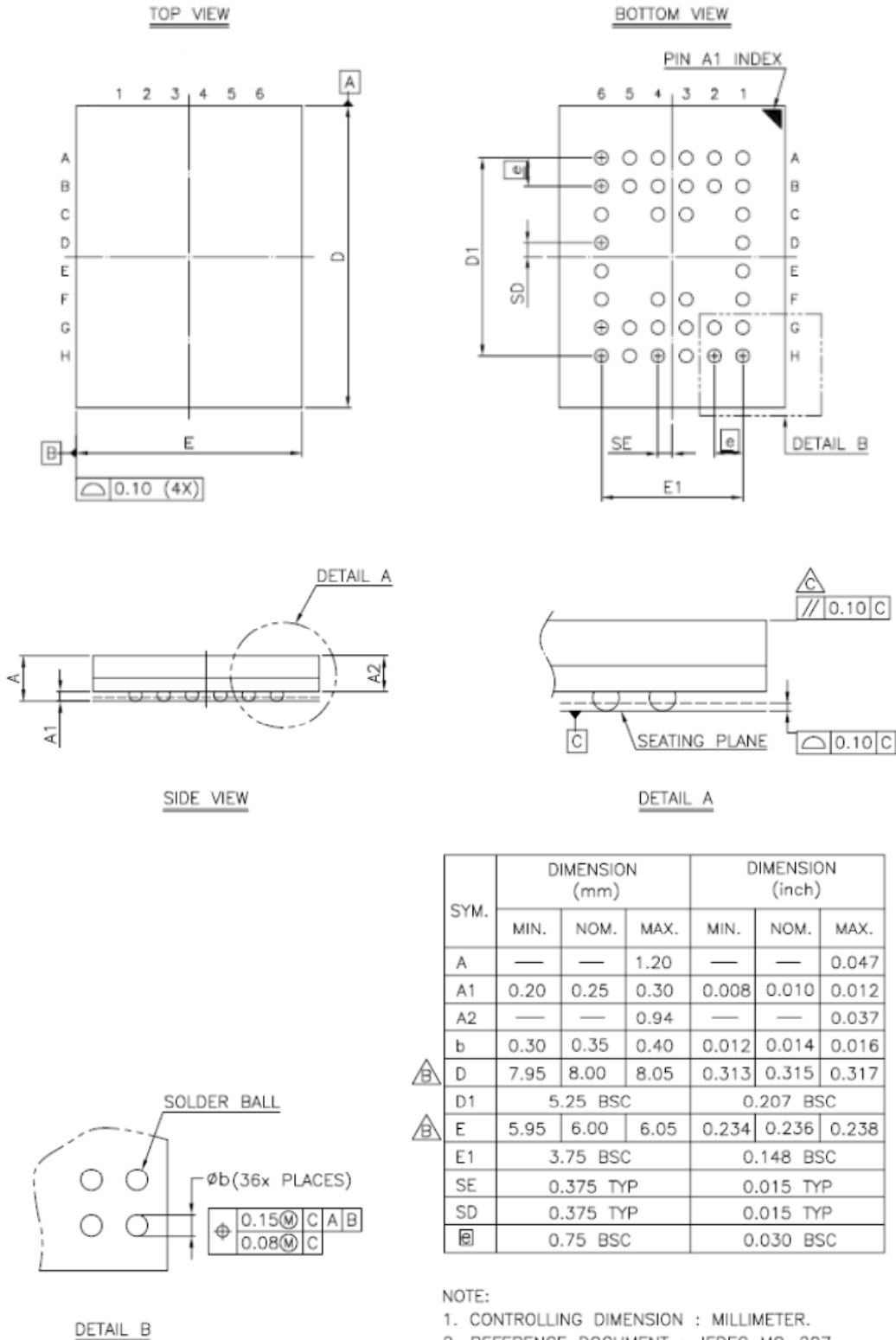

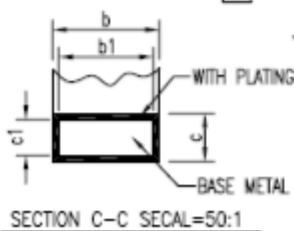
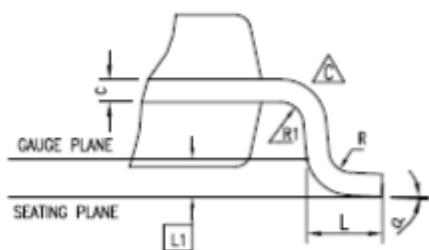
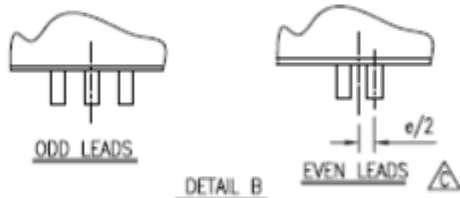
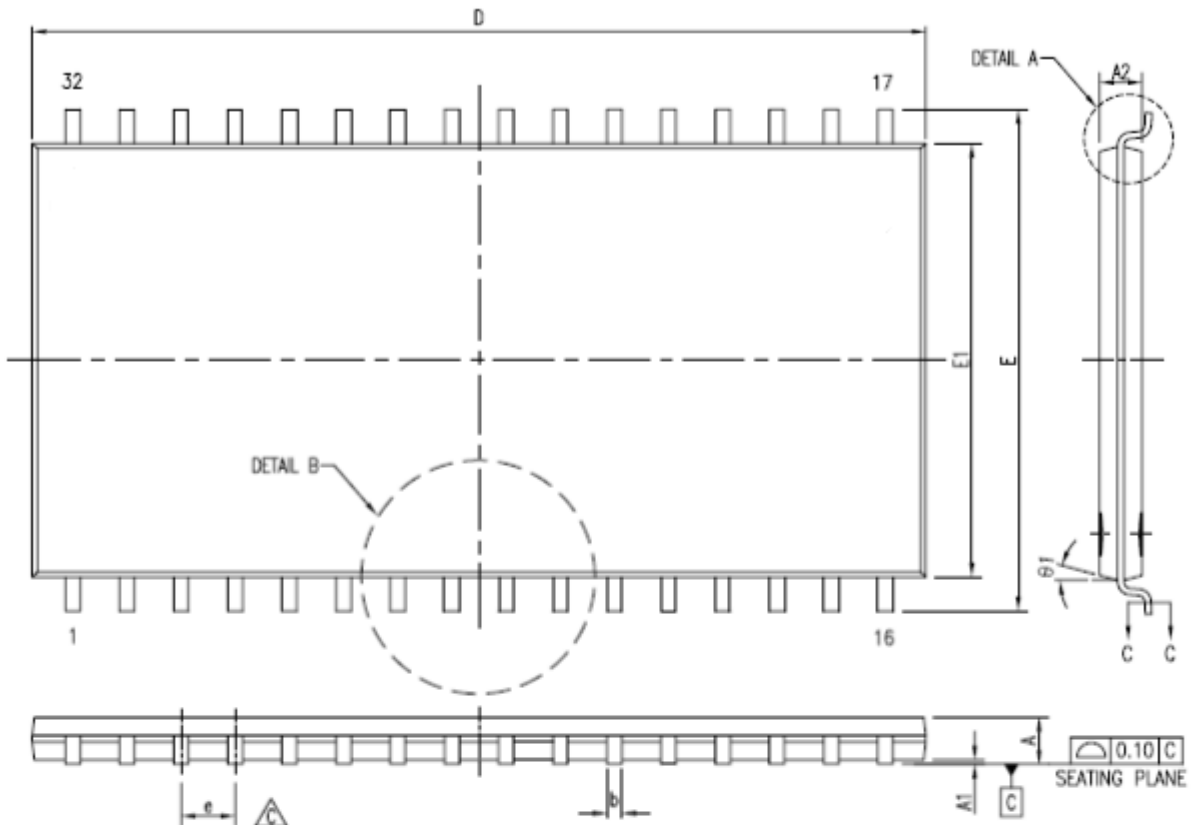
32-pin 400mil TSOP-II Package Outline Dimension

SYMBOL	DIMENSION IN MM			DIMENSION IN INCH		
	MIN.	NOM.	MAX.	MIN.	NOM.	MAX.
A			1.20			0.047
A1	0.05		0.15	0.002		0.006
A2	0.95	1.00	1.05	0.037	0.039	0.041
c	0.10	---	0.21	0.004	---	0.008
c1	0.10	---	0.16	0.004	---	0.006
D	20.82	20.95	21.08	0.820	0.825	0.830
E	11.56	11.76	11.96	0.455	0.463	0.471
E1	10.03	10.16	10.29	0.395	0.400	0.405
L	0.40	0.50	0.60	0.016	0.020	0.024
L1	0.25 BASIC			0.010 BASIC		
R	0.12	---	0.35	0.005	---	0.014
R1	0.12	---	---	0.005	---	---
θ	0		8	0		8
θ1	10	15	20	10	15	20

N	32L			50L		
e	1.27 BASIC			0.80 BASIC		
b	0.30	---	0.52	0.30	---	0.45
b1	0.30	0.40	0.45	0.30	0.35	0.40
JEDEC	MS-024(BA)			MS-024(BC)		

NOTE : DIMENSIONS D AND E1 DO NOT INCLUDE MOLD PROTRUSIONS.
 D AND E1 ARE MAXIMUM PLASTIC BODY SIZE DIMENSIONS INCLUDING MOLD MISMATCH.

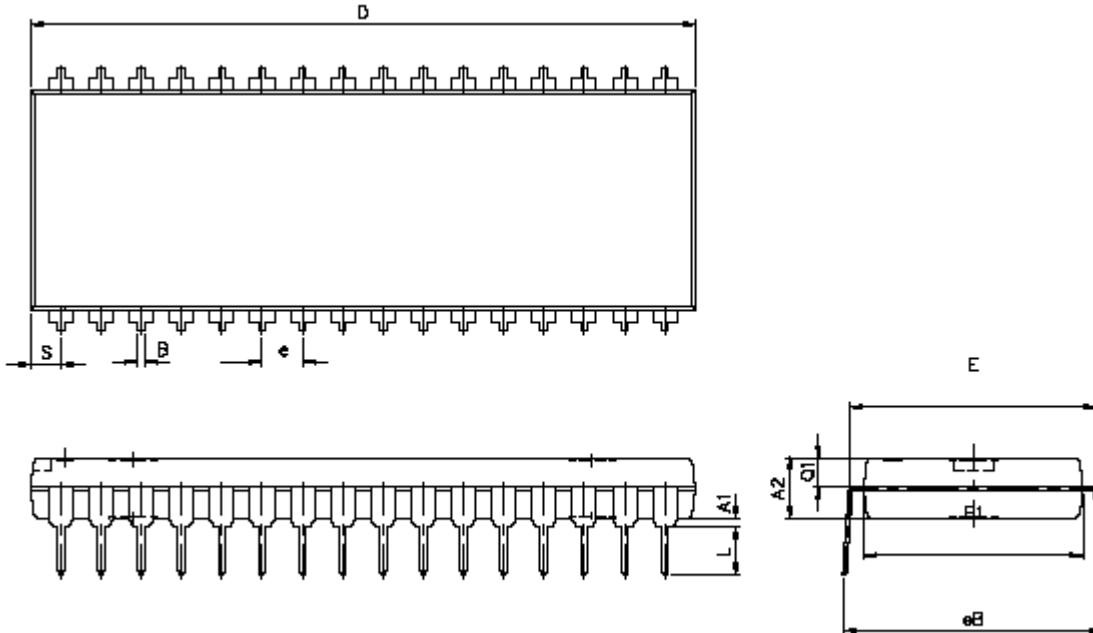
32 pin 600 mil P-DIP Package Outline Dimension

SYM.	UNIT	INCH(BASE)	MM(REF)
A1		0.015(MIN)	0.381(MIN)
A2		0.155±0.005	3.937±0.127
B		0.018±0.005	0.457±0.127
D		1.650±0.01	41.910±0.254
E		0.600±0.010	15.240±0.254
E1		0.545±0.005	13.843±0.127
e		0.100(TYP)	2.540(TYP)
eB		0.650±0.020	16.510±0.508.
L		0.158±0.043	4.013±1.092
S		0.075±0.010	1.905±0.254
Q1		0.070±0.005	1.778±0.127

Note : D/E1/S dimension do not include mold flash.



ORDERING INFORMATION

LY62W5128 U V - WW XX Y Z

Z : Packing Type

Blank : Tube or Tray
Tube : 32-pin 450 mil SOP
32-pin 600 mil P-DIP
Tray : 32-pin 8 mm x 20 mm TSOP-I
32-pin 8 mm x 13.4 mm STSOP
36-ball 6 mm x 8 mm TFBGA
32-pin 400 mil TSOP-II
T : Tape Reel

Y : Temperature Range

Blank : (Commercial) 0°C ~ 70°C
I : (Industrial) -40°C ~ +85°C

XX : Power Type

LL : Ultra Low Power
SL : Special Ultra Low Power

WW : Access Time(Speed)

V : Lead Information

L : Green Package

U : Package Type

S : 32-pin 450 mil SOP
L : 32-pin 8 mm x 20 mm TSOP-I
R : 32-pin 8 mm x 13.4 mm STSOP
G : 36-ball 6 mm x 8 mm TFBGA
W : 32-pin 400 mil TSOP-II
P : 32-pin 600 mil P-DIP



Lyontek Inc.

LY62W5128

Rev. 1.10

512K X 8 BIT LOW POWER CMOS SRAM

THIS PAGE IS LEFT BLANK INTENTIONALLY.