



REVISION HISTORY

<u>Revision</u>	<u>Description</u>	<u>Issue Date</u>
Rev. 1.0	Initial Issue	Sep.08.2020
Rev. 1.1	Revised ORDERING INFORMATION in page 14	Aug.30.2021
Rev. 1.2	Revised ORDERING INFORMATION in page 14 PKG type : Added 32(400mil) TSOPII & Deleted 32(600mil) PDIP Revised $I_{CC}(55ns)_{typ}=10mA$; $I_{CC}(55ns)_{max}=18mA$ in page 4 Revised $I_{SB}(SL)_{max}=8.0uA$ & $I_{DR}(SL)_{max}=8.0uA$ in page 4 & 8	Oct.19.2023
Rev.1.3	1.Revised DC ELECTRICAL CHARACTERISTICS :Standby Power Supply Current: $I_{SB1} : SL(MAX.)8 \rightarrow 7$, Deleted $SLE \rightarrow SLI(MAX.)12 \rightarrow 10$ in Page4 2.Revised DATA RETENTION CHARACTERISTICS : Data Retention Current: $I_{DR} :$ $SL(MAX.)8 \rightarrow 7$, $SLI(MAX.)12 \rightarrow 10$ in Page8	Apr.21.2025
Rev.1.4	Revised Typo error of PACKAGE OUTLINE DIMENSION : 32 pin 8mm x 20mm TSOP I L1 in page 10	Aug.11.2025
Rev.1.5	Deleted 32-pin 8mm x 20mm TSOP I in FEATURES --- Page1	Feb.25.2026
Rev.1.6	Revised 32-pin 8mm x 20mm TSOP I in FEATURES --- Page1	Apr.27.2026

FEATURES

- Fast access time : 45/55ns
- Low power consumption:
Operating current : 12/10mA (TYP.)
Standby current : 1.8 μ A (TYP.)
- Single 2.7V ~ 3.6V power supply
- All inputs and outputs TTL compatible
- Fully static operation
- Tri-state output
- Data retention voltage : 1.5V (MIN.)
- **Green package available**
- Package : 32-pin 450 mil SOP
 - 32-pin 8mm x 13.4mm sTSOP
 - 32-pin 400 mil TSOP II
 - 36-ball 6mm x 8mm TFBGA
 - 32-pin 8mm x 20mm TSOP I

GENERAL DESCRIPTION

The LY62L5128B is a 4,194,304-bit low power CMOS static random access memory organized as 524,288 words by 8 bits. It is fabricated using very high performance, high reliability CMOS technology. Its standby current is stable within the range of operating temperature.

The LY62L5128B is well designed for very low power system applications, and particularly well suited for battery back-up nonvolatile memory application.

The LY62L5128B operates from a single power supply of 2.7V ~ 3.6V and all inputs and outputs are fully TTL compatible

PRODUCT FAMILY

Product Family	Operating Temperature	V _{CC} Range	Speed	Power Dissipation	
				Standby(I _{SB1} , TYP.)	Operating(I _{CC} , TYP.)
LY62L5128B	0 ~ 70°C	2.7 ~ 3.6V	45/55ns	1.8 μ A	12/10mA
LY62L5128B(I)	-40 ~ 85°C	2.7 ~ 3.6V	45/55ns	1.8 μ A	12/10mA

FUNCTIONAL BLOCK DIAGRAM

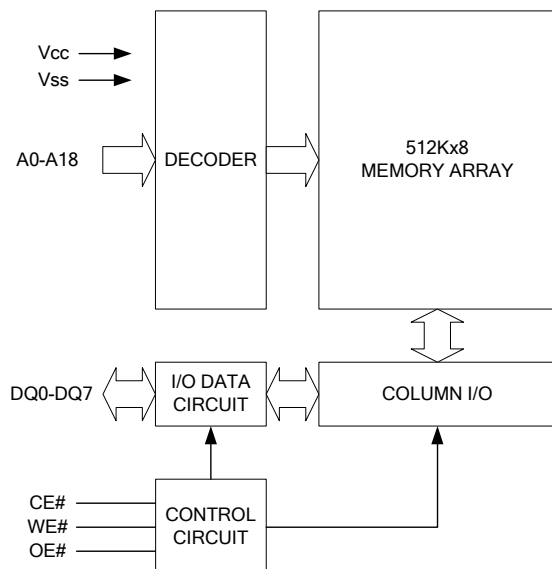

PIN DESCRIPTION

SYMBOL	DESCRIPTION
A0 - A18	Address Inputs
DQ0 - DQ7	Data Inputs/Outputs
CE#	Chip Enable Inputs
WE#	Write Enable Input
OE#	Output Enable Input
V _{CC}	Power Supply
V _{SS}	Ground
NC	No Connection



PIN CONFIGURATION

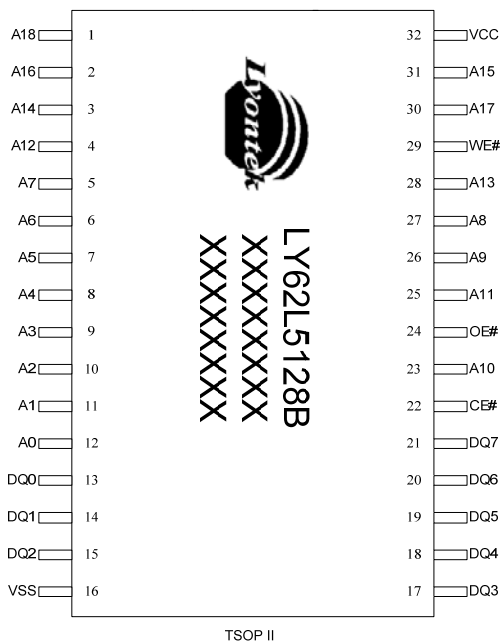
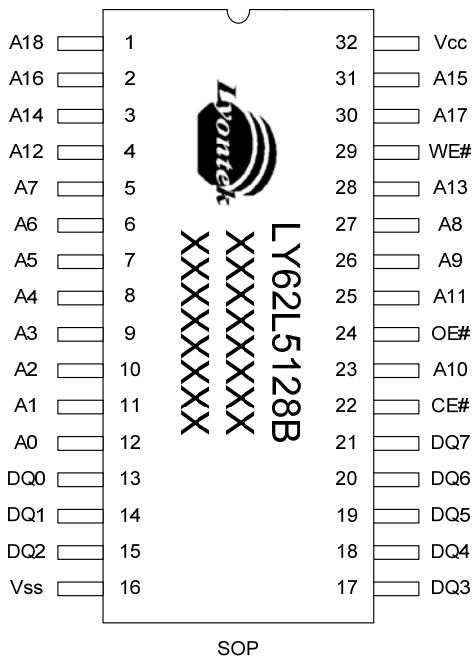

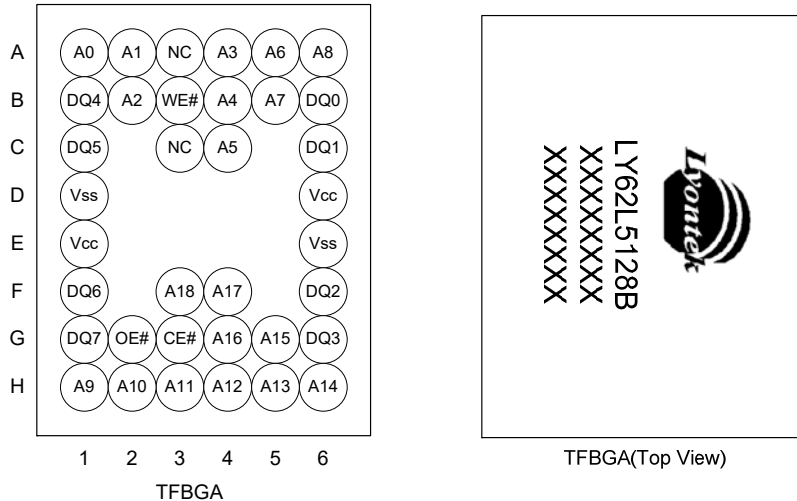
PIN CONFIGURATION

ABSOLUTE MAXIMUM RATINGS*

PARAMETER	SYMBOL	RATING	UNIT
Voltage on V_{CC} relative to V_{SS}	V_{T1}	-0.5 to 4.6	V
Voltage on any other pin relative to V_{SS}	V_{T2}	-0.5 to $V_{CC}+0.5$	V
Operating Temperature	T_A	0 to 70(C grade)	°C
		-40 to 85(I grade)	
Storage Temperature	T_{STG}	-65 to 150	°C
Power Dissipation	P_D	1	W
DC Output Current	I_{OUT}	50	mA

*Stresses greater than those listed under "Absolute Maximum Ratings" may cause permanent damage to the device. This is a stress rating only and functional operation of the device or any other conditions above those indicated in the operational sections of this specification is not implied. Exposure to the absolute maximum rating conditions for extended period may affect device reliability.

TRUTH TABLE

MODE	CE#	OE#	WE#	I/O OPERATION	SUPPLY CURRENT
Standby	H	X	X	High-Z	I_{SB1}
Output Disable	L	H	H	High-Z	I_{CC}, I_{CC1}
Read	L	L	H	D_{OUT}	I_{CC}, I_{CC1}
Write	L	X	L	D_{IN}	I_{CC}, I_{CC1}

Note: H = V_{IH} , L = V_{IL} , X = Don't care.



DC ELECTRICAL CHARACTERISTICS

PARAMETER	SYMBOL	TEST CONDITION	MIN.	TYP. ^{*4}	MAX.	UNIT		
Supply Voltage	V _{CC}		2.7	3.0	3.6	V		
Input High Voltage	V _{IH} ^{*1}		2.2	-	V _{CC} +0.3	V		
Input Low Voltage	V _{IL} ^{*2}		- 0.2	-	0.6	V		
Input Leakage Current	I _{LI}	V _{CC} ≥ V _{IN} ≥ V _{SS}	- 1	-	1	μA		
Output Leakage Current	I _{LO}	V _{CC} ≥ V _{OUT} ≥ V _{SS} , Output Disabled	- 1	-	1	μA		
Output High Voltage	V _{OH}	I _{OH} = -1mA	2.2	2.7	-	V		
Output Low Voltage	V _{OL}	I _{OL} = 2mA	-	-	0.4	V		
Average Operating Power supply Current	I _{CC}	Cycle time = Min. CE# ≤ 0.2V, I _{I/O} = 0mA Others at 0.2V or V _{CC} -0.2V	- 45	-	12	20	mA	
			- 55	-	10	18	mA	
	I _{CC1}	Cycle time = 1μs CE# ≤ 0.2V, I _{I/O} = 0mA Other pins at 0.2V or V _{CC} -0.2V	-	2	4	mA		
Standby Power Supply Current	I _{SB1}	CE# ≥ V _{CC} -0.2V Others at 0.2V or V _{CC} - 0.2V	SL ^{*5}	25°C	-	1.8	4	μA
			SLI ^{*5}	40°C	-	2	4.5	μA
			SL		-	1.8	7	μA
			SLI		-	1.8	10	μA

Notes:

- V_{IH(max)} = V_{CC} + 3.0V for pulse width less than 10ns.
- V_{IL(min)} = V_{SS} - 3.0V for pulse width less than 10ns.
- Over/Undershoot specifications are characterized on engineering evaluation stage, not for mass production test.
- Typical values are included for reference only and are not guaranteed or tested.
Typical values are measured at V_{CC} = V_{CC(TYP.)} and T_A = 25°C
- This parameter is measured at V_{CC} = 3.0V

CAPACITANCE (T_A = 25°C, f = 1.0MHz)

PARAMETER	SYMBOL	MIN.	MAX	UNIT
Input Capacitance	C _{IN}	-	6	pF
Input/Output Capacitance	C _{I/O}	-	8	pF

Note : These parameters are guaranteed by device characterization, but not production tested.

AC TEST CONDITIONS

Input Pulse Levels	0.2V to V _{CC} - 0.2V
Input Rise and Fall Times	3ns
Input and Output Timing Reference Levels	1.5V
Output Load	C _L = 30pF + 1TTL, I _{OH} /I _{OL} = -1mA/2mA



AC ELECTRICAL CHARACTERISTICS

(1) READ CYCLE

PARAMETER	SYM.	LY62L5128B-45		LY62L5128B-55		UNIT
		MIN.	MAX.	MIN.	MAX.	
Read Cycle Time	t _{RC}	45	-	55	-	ns
Address Access Time	t _{AA}	-	45	-	55	ns
Chip Enable Access Time	t _{ACE}	-	45	-	55	ns
Output Enable Access Time	t _{OE}	-	25	-	30	ns
Chip Enable to Output in Low-Z	t _{CLZ} *	10	-	10	-	ns
Output Enable to Output in Low-Z	t _{OLZ} *	5	-	5	-	ns
Chip Disable to Output in High-Z	t _{CHZ} *	-	15	-	20	ns
Output Disable to Output in High-Z	t _{OHZ} *	-	15	-	20	ns
Output Hold from Address Change	t _{OH}	10	-	10	-	ns

(2) WRITE CYCLE

PARAMETER	SYM.	LY62L5128B-45		LY62L5128B-55		UNIT
		MIN.	MAX.	MIN.	MAX.	
Write Cycle Time	t _{WC}	45	-	55	-	ns
Address Valid to End of Write	t _{AW}	40	-	50	-	ns
Chip Enable to End of Write	t _{CW}	40	-	50	-	ns
Address Set-up Time	t _{AS}	0	-	0	-	ns
Write Pulse Width	t _{WP}	35	-	45	-	ns
Write Recovery Time	t _{WR}	0	-	0	-	ns
Data to Write Time Overlap	t _{DW}	20	-	25	-	ns
Data Hold from End of Write Time	t _{DH}	0	-	0	-	ns
Output Active from End of Write	t _{OW} *	5	-	5	-	ns
Write to Output in High-Z	t _{WHZ} *	-	15	-	20	ns

*These parameters are guaranteed by device characterization, but not production tested.

TIMING WAVEFORMS

READ CYCLE 1 (Address Controlled) (1,2)

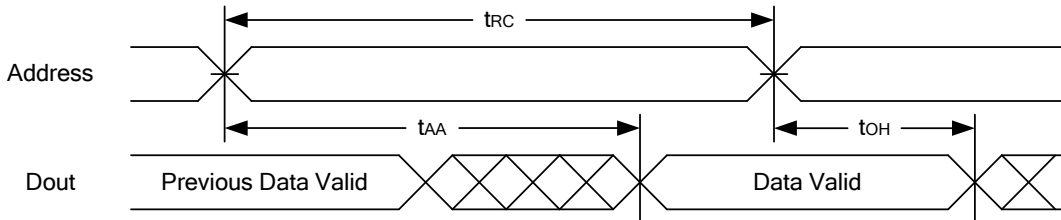

READ CYCLE 2 (CE# and OE# Controlled) (1,3,4,5)

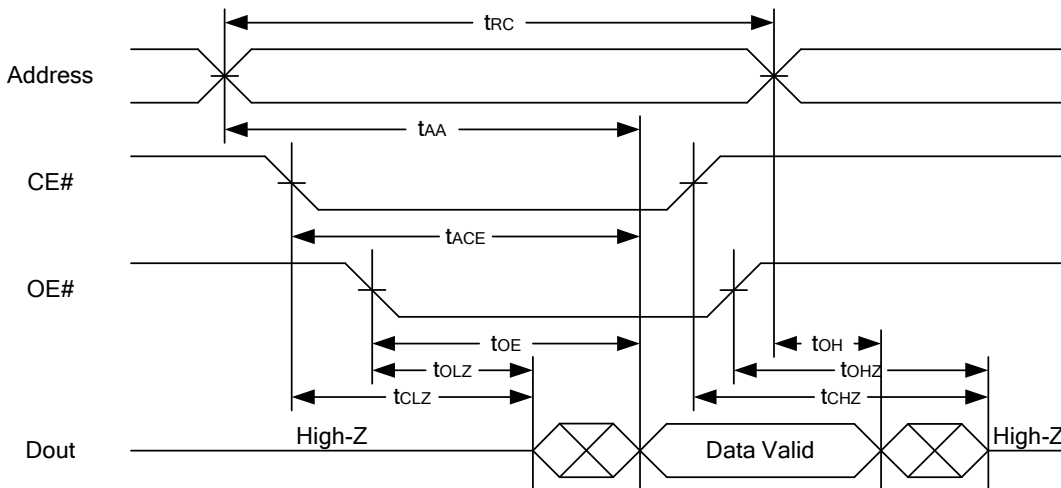

Notes :

1. WE# is high for read cycle.
2. Device is continuously selected OE# = low, CE# = low.
3. Address must be valid prior to or coincident with CE# = low,; otherwise t_{AA} is the limiting parameter.
4. t_{CLZ} , t_{OLZ} , t_{CHZ} and t_{OHZ} are specified with $C_L = 5pF$. Transition is measured $\pm 500mV$ from steady state.
5. At any given temperature and voltage condition, t_{CHZ} is less than t_{CLZ} , t_{OHZ} is less than t_{OLZ} .



WRITE CYCLE 1 (WE# Controlled) (1,2,4,5)

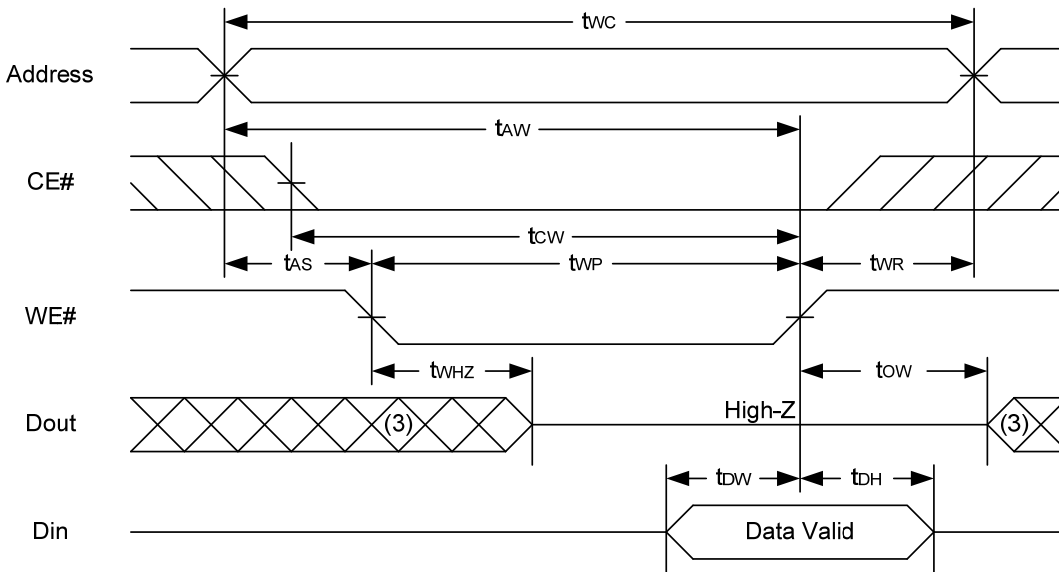

WRITE CYCLE 2 (CE# Controlled) (1,4,5)

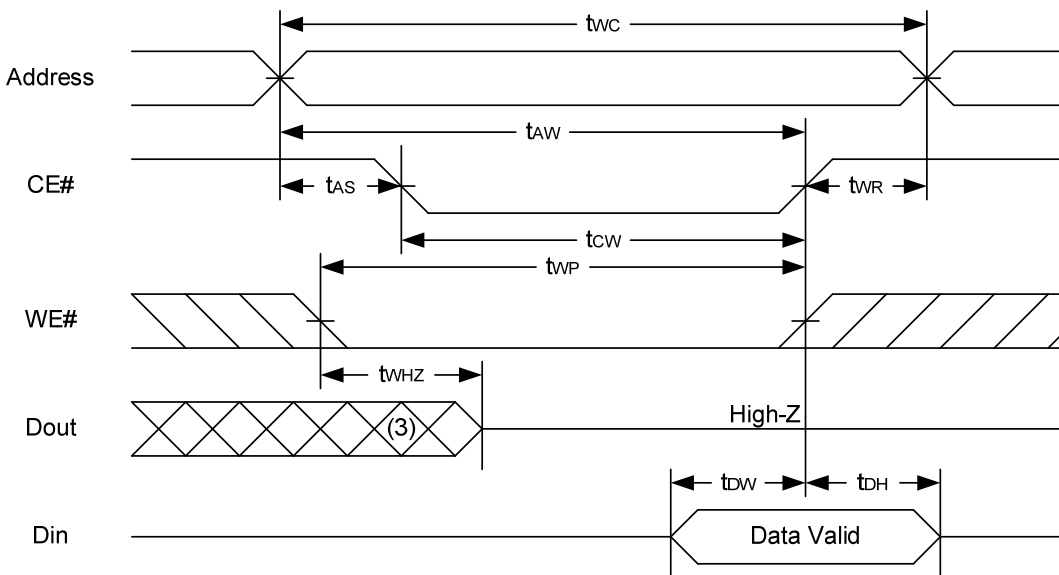

Notes :

1. A write occurs during the overlap of a low CE#, low WE#.
2. During a WE# controlled write cycle with OE# low, t_{WP} must be greater than t_{WHZ} + t_{DW} to allow the drivers to turn off and data to be placed on the bus.
3. During this period, I/O pins are in the output state, and input signals must not be applied.
4. If the CE# low transition occurs simultaneously with or after WE# low transition, the outputs remain in a high impedance state.
5. t_{OW} and t_{WHZ} are specified with C_L = 5pF. Transition is measured ±500mV from steady state.



DATA RETENTION CHARACTERISTICS

PARAMETER	SYMBOL	TEST CONDITION	MIN.	TYP.	MAX.	UNIT		
V _{CC} for Data Retention	V _{DR}	CE# ≥ V _{CC} -0.2V	1.5	-	3.6	V		
Data Retention Current	I _{DR}	V _{CC} = 1.5V CE# ≥ V _{CC} -0.2V Other pins at 0.2V or V _{CC} -0.2V	SL	25°C	-	1.8	4	μA
			SLI	40°C	-	2	4.5	μA
			SL		-	1.8	7	μA
			SLI		-	1.8	10	μA
Chip Disable to Data Retention Time	t _{CDR}	See Data Retention Waveforms (below)	0	-	-	ns		
Recovery Time	t _R		t _{RC} *	-	-	ns		

t_{RC}* = Read Cycle Time

DATA RETENTION WAVEFORM

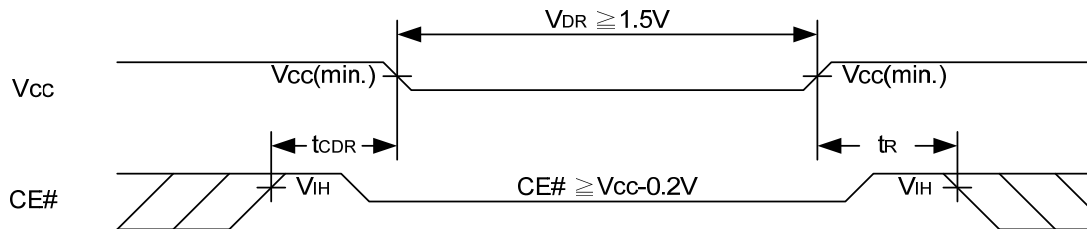



PACKAGE OUTLINE DIMENSION

32 pin 450 mil SOP Package Outline Dimension

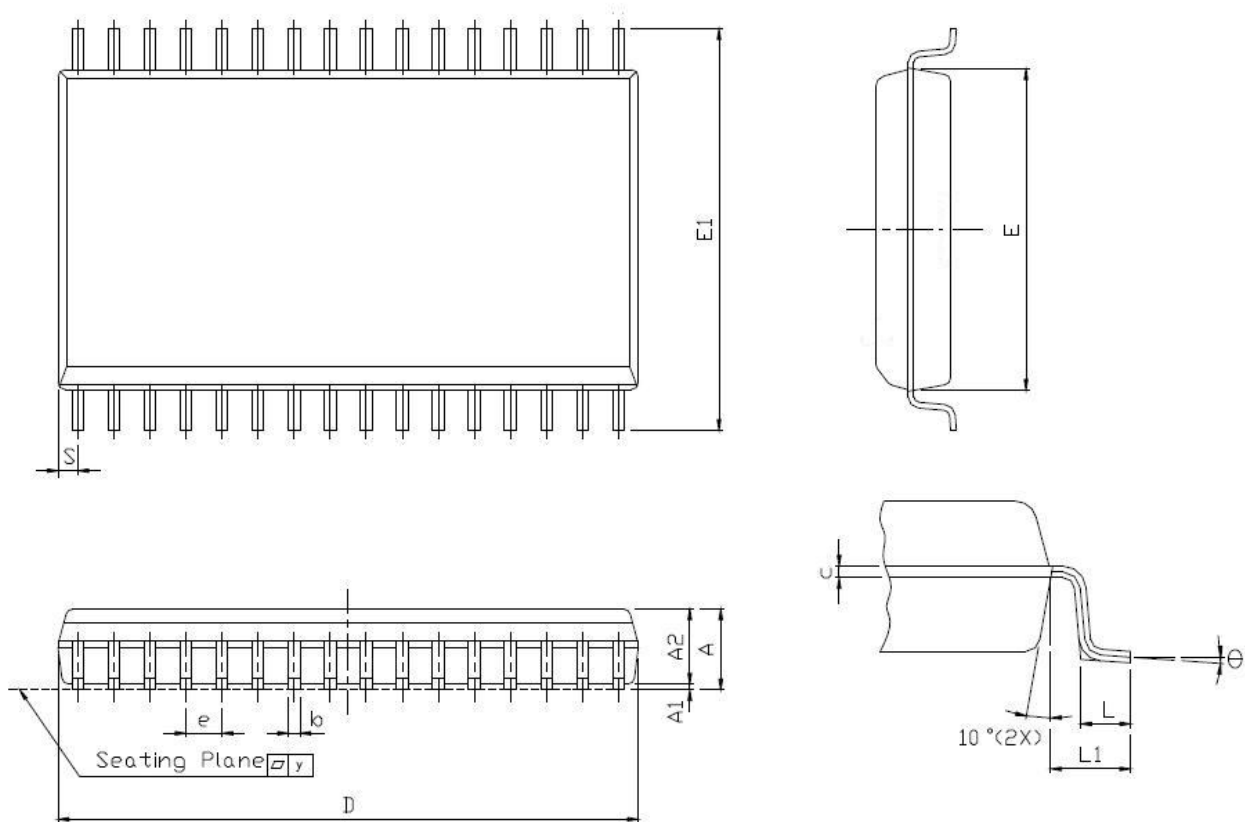

SYM.	UNIT	INCH.(BASE)	MM(REF)
A		0.120(MAX)	3.048(MAX)
A1		0.004(MIN)	0.102(MIN)
A2		0.116(MAX)	2.946(MAX)
b		0.016(TYP)	0.406(TYP)
c		0.008(TYP)	0.203(TYP)
D		0.817(MAX)	20.75(MAX)
E		0.445±0.006	11.303±0.152
E1		0.555±0.025	14.097±0.635
e		0.050(TYP)	1.270(TYP)
L		0.033±0.017	0.838±0.432
L1		0.055±0.008	1.397±0.203
S		0.026(MAX)	0.660(MAX)
y		0.004(MAX)	0.101(MAX)
Θ		0° -10°	0° -10°



32 pin 8mm x 13.4mm sTSPQ Package Outline Dimension

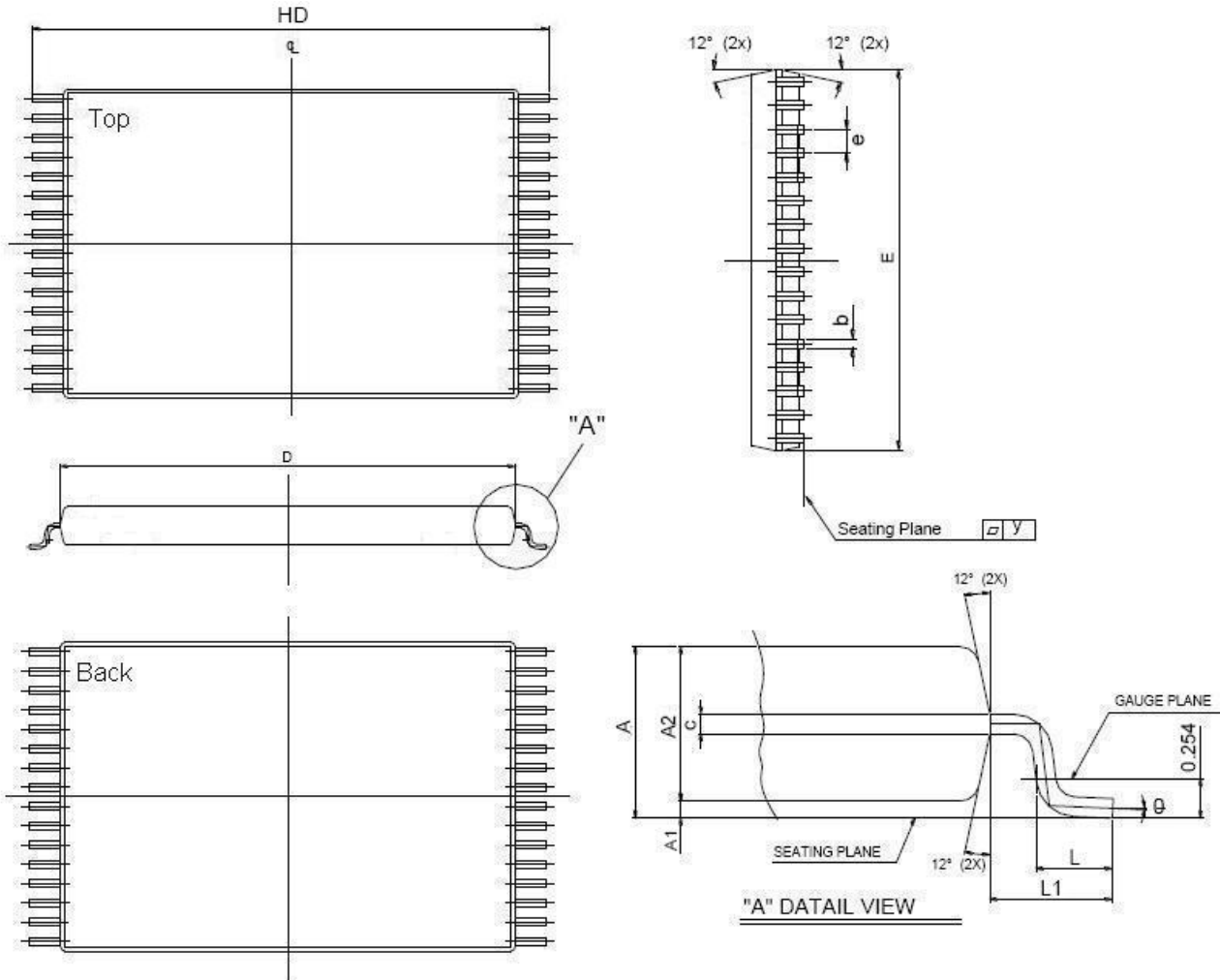

SYM.	UNIT	INCH(BASE)	MM(REF)
A		0.049 (MAX)	1.25 (MAX)
A1		0.004 ±0.002	0.10 ±0.05
A2		0.039 ±0.002	1.00 ±0.05
b		0.009 ±0.002	0.22 ±0.05
c		0.006 ±0.002	0.155 ±0.055
D		0.465 ±0.008	11.80 ±0.20
E		0.315 ±0.008	8.00 ±0.20
e		0.020 (TYP)	0.50 (TYP)
HD		0.528±0.008	13.40 ±0.20.
L		0.02 ±0.008	0.50 ±0.20
L1		0.031 ±0.005	0.8 ±0.125
y		0.003 (MAX)	0.076 (MAX)
∅		0°~5°	0°~5°

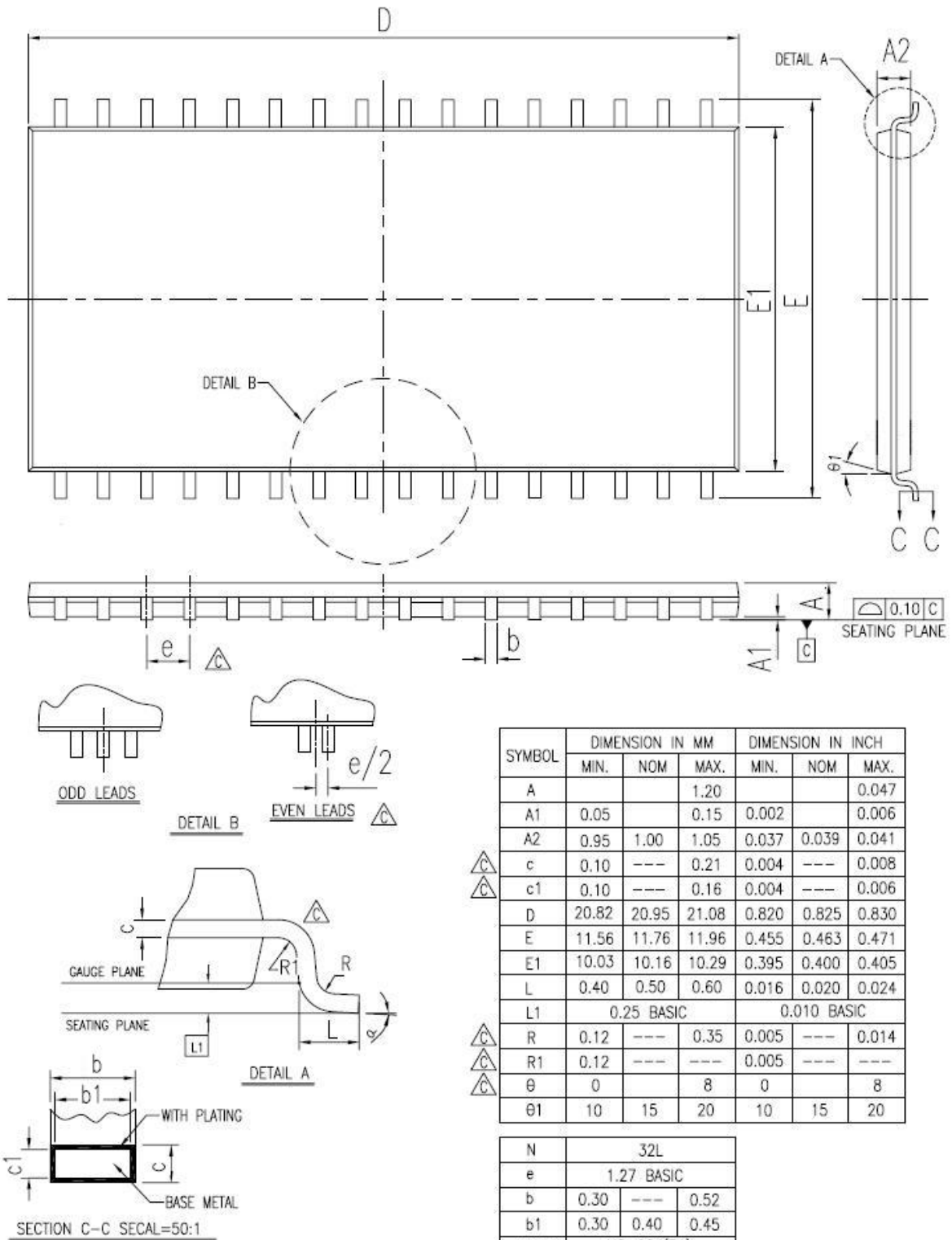
32-pin 400mil TSOP II Package Outline Dimension

NOTE : DIMENSIONS D AND E1 DO NOT INCLUDE MOLD PROTRUSIONS.
D AND E1 ARE MAXIMUM PLASTIC BODY SIZE DIMENSIONS INCLUDING MOLD MISMATCH.

36 ball 6mm × 8mm TFBGA Package Outline Dimension

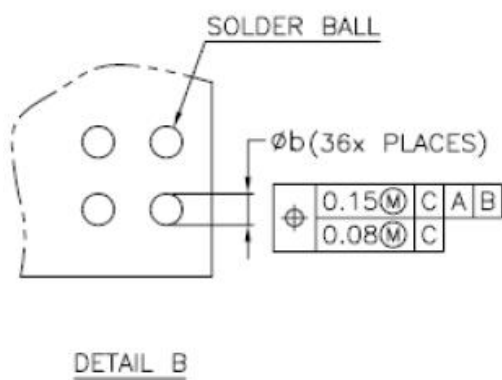
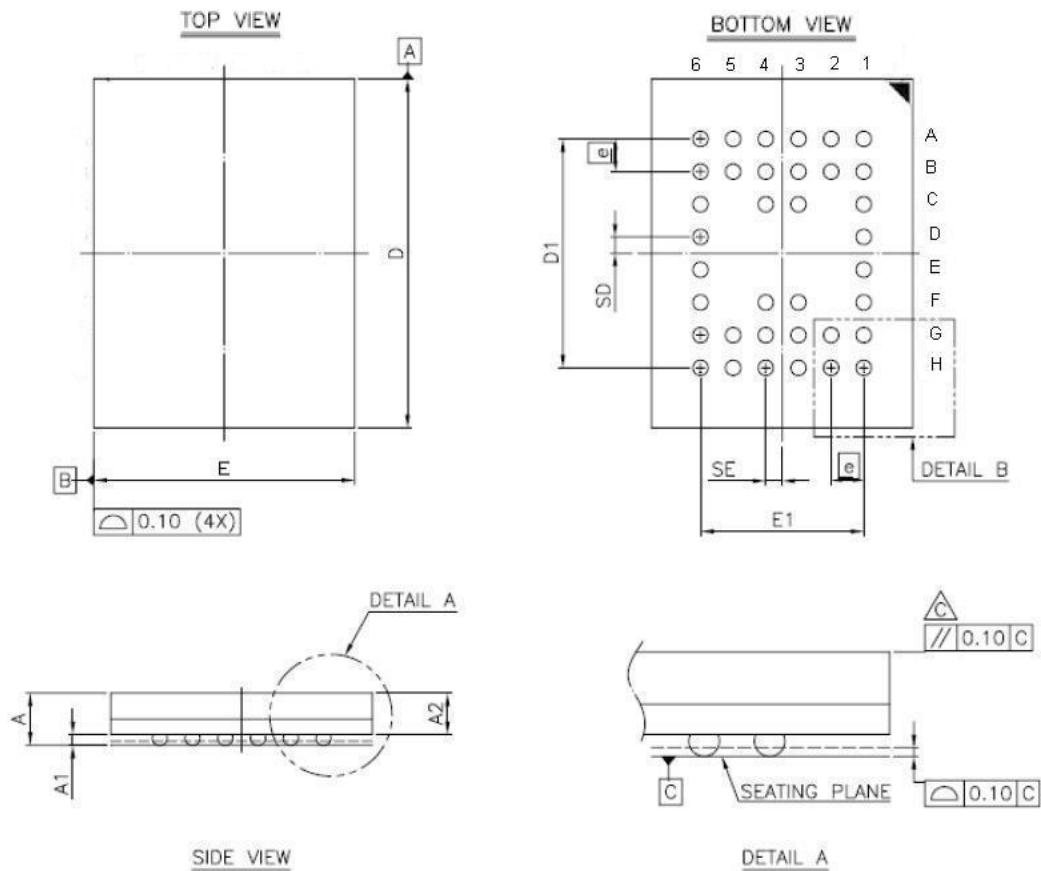

SYM.	DIMENSION (mm)			DIMENSION (inch)		
	MIN.	NOM.	MAX.	MIN.	NOM.	MAX.
A	—	—	1.20	—	—	0.047
A1	0.20	0.25	0.30	0.008	0.010	0.012
A2	—	—	0.94	—	—	0.037
b	0.30	0.35	0.40	0.012	0.014	0.016
D	7.95	8.00	8.05	0.313	0.315	0.317
D1	5.25 BSC			0.207 BSC		
E	5.95	6.00	6.05	0.234	0.236	0.238
E1	3.75 BSC			0.148 BSC		
SE	0.375 TYP			0.015 TYP		
SD	0.375 TYP			0.015 TYP		
e	0.75 BSC			0.030 BSC		

NOTE:

1. CONTROLLING DIMENSION : MILLIMETER.
2. REFERENCE DOCUMENT : JEDEC MO-207.



32 pin 8mm x 20mm TSOP I Package Outline Dimension

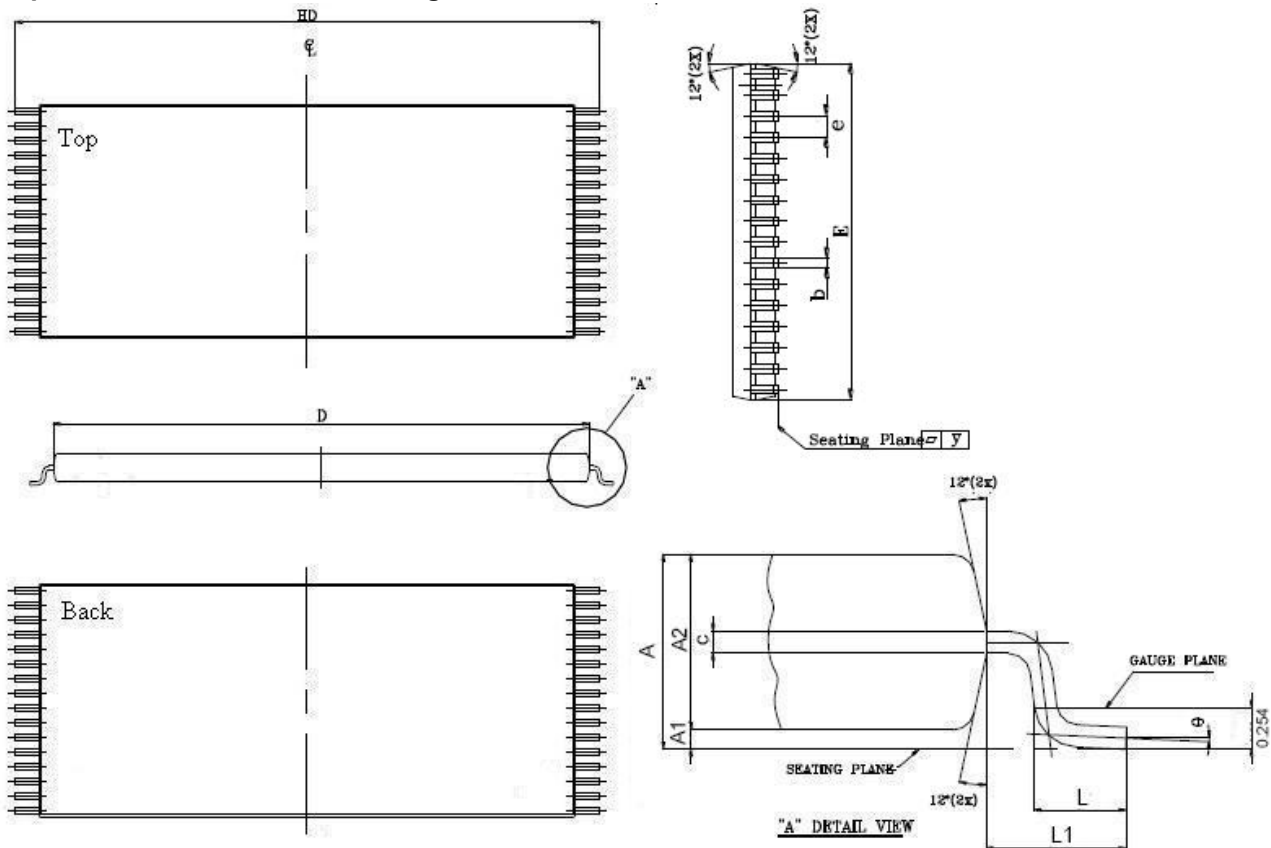

SYM.	UNIT	INCH(BASE)	MM(REF)
A		0.047 (MAX)	1.20 (MAX)
A1		0.004 ±0.002	0.10 ±0.05
A2		0.039 ±0.002	1.00 ±0.05
b		0.009 ±0.002	0.22 ±0.05
c		0.006 ±0.002	0.155 ±0.055
D		0.724 ±0.008	18.40 ±0.20
E		0.315 ±0.008	8.00 ±0.20
e		0.020 (TYP)	0.50 (TYP)
HD		0.787 ±0.008	20.00 ±0.20
L		0.024 ±0.004	0.60 ±0.10
L1		0.031 REF	0.8 REF
y		0.003 (MAX)	0.08 (MAX)
Θ		0°~5°	0°~5°



ORDERING INFORMATION

Package Type	Access Time (Speed)(ns)	Power Type	Temperature Range(°C)	Packing Type	Lyontek Item No.
32Pin (8mmx13.4mm) sTSOP	45	Special	0°C~70°C	Tray	LY62L5128BRL-45SL
				Tape Reel	LY62L5128BRL-45SLT
		Ultra Low Power	-40°C~85°C	Tray	LY62L5128BRL-45SLI
				Tape Reel	LY62L5128BRL-45SLIT
	55	Special	0°C~70°C	Tray	LY62L5128BRL-55SL
				Tape Reel	LY62L5128BRL-55SLT
		Ultra Low Power	-40°C~85°C	Tray	LY62L5128BRL-55SLI
				Tape Reel	LY62L5128BRL-55SLIT
32-pin(450mil) SOP	45	Special	0°C~70°C	Tray	LY62L5128BSL-45SL
				Tape Reel	LY62L5128BSL-45SLT
		Ultra Low Power	-40°C~85°C	Tray	LY62L5128BSL-45SLI
				Tape Reel	LY62L5128BSL-45SLIT
	55	Special	0°C~70°C	Tray	LY62L5128BSL-55SL
				Tape Reel	LY62L5128BSL-55SLT
		Ultra Low Power	-40°C~85°C	Tray	LY62L5128BSL-55SLI
				Tape Reel	LY62L5128BSL-55SLIT
32-pin (8mm x 20mm) TSOP I	45	Special	0°C~70°C	Tray	LY62L5128BLL-45SL
				Tape Reel	LY62L5128BLL-45SLT
		Ultra Low Power	-40°C~85°C	Tray	LY62L5128BLL-45SLI
				Tape Reel	LY62L5128BLL-45SLIT
	55	Special	0°C~70°C	Tray	LY62L5128BLL-55SL
				Tape Reel	LY62L5128BLL-55SLT
		Ultra Low Power	-40°C~85°C	Tray	LY62L5128BLL-55SLI
				Tape Reel	LY62L5128BLL-55SLIT
32Pin(400mil) TSOP II	45	Special	0°C~70°C	Tray	LY62L5128BWL-45SL
				Tape Reel	LY62L5128BWL-45SLT
		Ultra Low Power	-40°C~85°C	Tray	LY62L5128BWL-45SLI
				Tape Reel	LY62L5128BWL-45SLIT
	55	Special	0°C~70°C	Tray	LY62L5128BWL-55SL
				Tape Reel	LY62L5128BWL-55SLT
		Ultra Low Power	-40°C~85°C	Tray	LY62L5128BWL-55SLI
				Tape Reel	LY62L5128BWL-55SLIT
36-ball (6mm x 8mm) TFBGA	45	Special	0°C~70°C	Tray	LY62L5128BGL-45SL
				Tape Reel	LY62L5128BGL-45SLT
		Ultra Low Power	-40°C~85°C	Tray	LY62L5128BGL-45SLI
				Tape Reel	LY62L5128BGL-45SLIT
	55	Special	0°C~70°C	Tray	LY62L5128BGL-55SL
				Tape Reel	LY62L5128BGL-55SLT
		Ultra Low Power	-40°C~85°C	Tray	LY62L5128BGL-55SLI
				Tape Reel	LY62L5128BGL-55SLIT



Lyontek Inc.

LY62L5128B

Rev. 1.6

512K X 8 BIT LOW POWER CMOS SRAM

THIS PAGE IS LEFT BLANK INTENTIONALLY.